

LIUGONG

913/915FCR EXCAVATOR

ALL NEW
F-SERIES

Engine	Cummins B6.7
Net Power	69.5 / 84.5 kW
913FCR Weight	14,700 - 16,100kg
915FCR Weight	15,400 - 17,300kg
Bucket Capacity	0.77m ³



TOUGH WORLD. TOUGH EQUIPMENT.

“ THE BEST MACHINES ARE DESIGNED FOR BALANCE, NOT COMPROMISE... ”

YOUR PERFORMANCE DASHBOARD

Research tells us that 6 key performance areas really matter to you. We'd like to use this performance dashboard to present the real, tough facts about our all New 913FCR/915FCR.



TOUGHNESS & DURABILITY



POWER & EFFICIENCY



INTELLIGENCE & CONTROL



COMFORT & ERGONOMICS



SAFETY & VISIBILITY



UPTIME & MAINTENANCE

The all new 913FCR and 915FCR are packed with benefits. The 913FCR is brilliant at the basics giving you everything you want but nothing you don't need. When you want **EXTRA** performance the 915FCR delivers.

CUSTOMER DRIVEN DESIGN...

Our customers don't like compromise, nor do we. That's why we do our homework before we start the design process to really understand how our machines are actually owned and operated.

This insight allows us to perfectly balance, the demands of the machine owner and the machine operator but without compromise.



red dot design award

RED DOT AWARD-WINNING DESIGN

Our UK design team were recently recognized with a prestigious Red Dot Award for our new 4180D motor grader recognising its innovation and excellence in product design.



HERE'S THE BIG PICTURE...

The all new 913FCR - brilliant at the basics.
The new 915FCR delivers the extra.



POWER & EFFICIENCY

- 3 new power modes - Power, Standard and Eco
- Cummins VGT technology engine delivers 5% more torque

915FCR

EXTRA 15kW engine power



TOUGHNESS & DURABILITY

- Larger track rollers increases carrying capacity by 20%
- Tougher chassis reduces stress by 15%
- Tougher integrally cast boom and arm

915FCR

EXTRA Longer undercarriage

EXTRA 500kg counterweight

EXTRA 10% additional stability



INTELLIGENCE & CONTROL

- Electro-hydraulic control technology
- Attachment flow and pressure control
- Short tail swing radius

915FCR

EXTRA Two piece boom option



ALL NEW **F**SERIES

913/915FCR EXCAVATOR



SAFETY & VISIBILITY

- 360 degree camera
- Ground level daily inspection
- Anti-slip tread plates and fold down guard rails
- 1.52m tail swing radius reduces collision risk around the machine



UPTIME & MAINTENANCE

- 1000h air filter cycle
- Maintenance friendly design and layout gives easier access
- Plastic moulded fuel tank increases fuel tank capacity and prevent rust damage



COMFORT & ERGONOMICS

- F-Series Ergonomic cab design
- Intuitive operator interfaces & control
- Quiet (72dBA) and clean (pressurised environment)



NOW FOR THE DETAIL...

**“ NO MATTER WHAT YOU DO
TO TRUST YOUR MACHINE 100%**



**NO, YOU'VE GOT
100% ”**



TOUGHNESS AND DURABILITY

DESIGNED TO WORK HARDER, FOR LONGER



DESIGNED TO WORK HARDER, FOR LONGER...

To build machines that can withstand the hardest conditions takes intelligent design, and attention to detail. We know that a machine is only as strong as its weakest point, so every weld, every joint, every component is scrutinized to ensure it passes our rigorous durability tests. **Here's the proof.**



TOUGHNESS AND DURABILITY

1. STRONGER CHASSIS

We've increased the size of our upper and lower track rollers to reduce the stress by 8% and increase the carrying capacity by 20% respectively.

2. GROUND PROTECTION

Our machines may be tough, but with the optional rubber block tracks they're soft on the surface to avoid unnecessary damage.

3. EXTRA VIGILANCE

100% flaw detection ensures every weld is checked to meet our stringent standards.

4. INCREASED DURABILITY

Choose from our range of performance and durability enhancing extras such as our easy to fit demolition guards and heavy duty counter-weight.

5. TOUGHER BOOM AND ARM

Finite element analysis proves the load efficiency and toughness of our boom and arm, but we go further to reduce stress by **50%**.

- Front and rear supports are cast, reducing welds and increasing torsional resistance
- Central ram pivot is forged to reduce stress
- EH hydraulic system reduces hoses and potential leak paths improving long-term performance

6. 915FCR EXTRA...

915FCR

EXTRA Longer undercarriage

EXTRA 500kg counterweight

EXTRA 10% additional stability

PERFORMANCE STATISTICS

1.

+10%

INCREASED STABILITY ON 915FCR

5.

+20%

INCREASED TRACK ROLLER CARRYING CAPACITY

5.

-50%

DIG END STRESS REDUCTION

1.

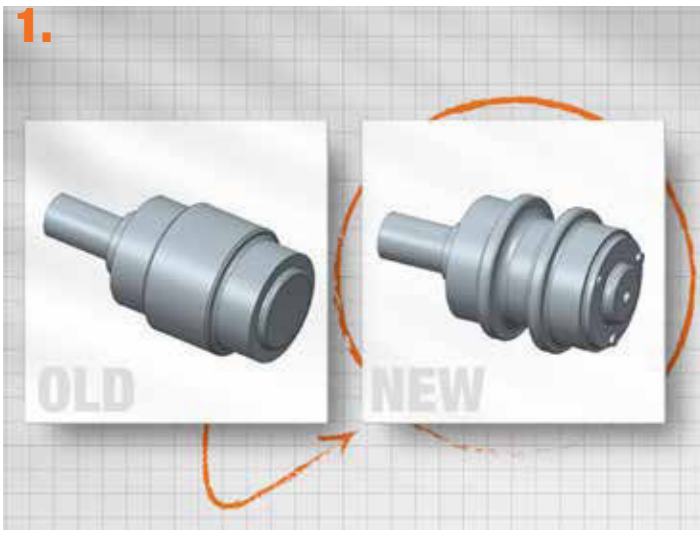

2.



3.



4.



5.

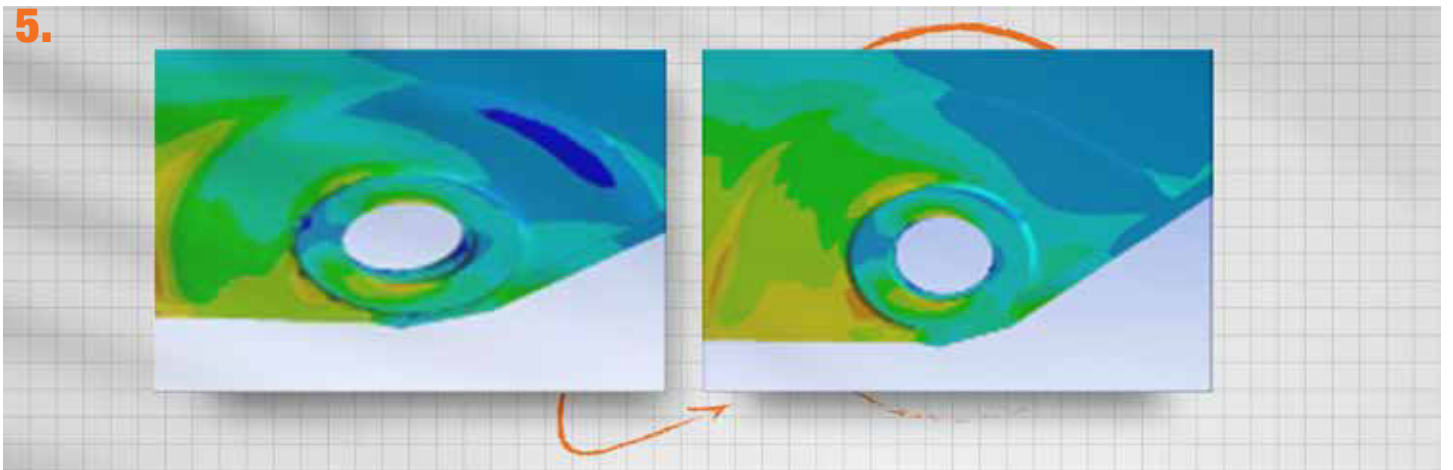

TOUGHNESS IS WHAT WE DO...

With over 50,000 excavators already working in the world's toughest environments, you can trust our machines to keep working harder - for longer.



**“ WHY CHOOSE BETWEEN P
EFFICIENCY WHEN YOU CAN**





POWER AND EFFICIENCY HAVE BOTH? ””



POWER AND EFFICIENCY
DESIGNED TO MOVE MORE, FOR LESS



DESIGNED TO MOVE MORE, FOR LESS...

There's no need to compromise digging performance to get the highest fuel efficiency because the all New 913FCR and 915FCR gives you both. With greater torque and more power at lower engine speeds you get the power you want and the fuel efficiency you need.



POWER AND EFFICIENCY

1. MORE REAL POWER

With VGT technology, the 3.8L Four Cylinder Cummins engine delivers 5% extra torque compared to high torque at low engine speeds. VGT enables the engine to maximize its power output whilst creating less noise and using less fuel.

2. EXCEED YOUR EXPECTATIONS

When it comes to efficiency, the 913FCR and 915FCR is smarter than you'd think. Feed Forward control technology matches the engine's speed to the operator's command and predicted load to deliver even greater fuel economy.

3. 915FCR EXTRA...

915FCR features an additional 15kW of engine power, providing extra performance in tougher ground conditions and when using larger attachments.

4. SAVE EVERY DROP OF FUEL

Engine Auto Idle and Auto Shutdown make every single drop of fuel count. Reducing unproductive fuel saves you money and helps protect the environment.

5. GEARING UP

Larger displacement slew motor and higher relief pressures allow 7% greater torque to increase cycle times*.

*compared to 915E

6. PUSHING PERFORMANCE

The optional dozer blade gives you extra stability and a multitasking capability to keep your site clean and level.

PERFORMANCE STATISTICS

1.

+5%

EXTRA TORQUE *

*compared to 915E

5.

+7%

GREATER SLEW TORQUE

5.

+15kW

ON 915FCR

1.

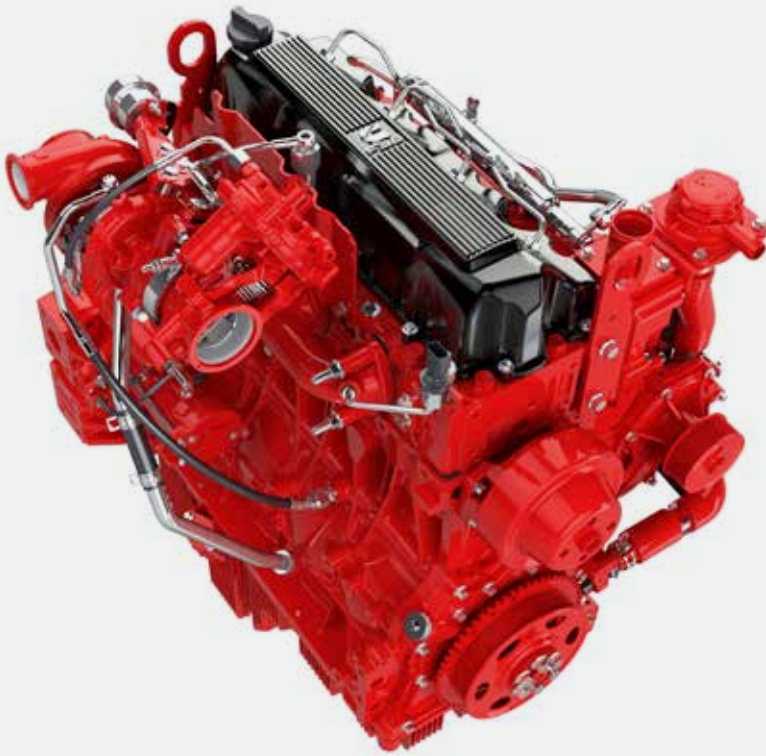

2.

FEED FORWARD

OPERATOR MOVES JOYSTICK



PREDICTED MACHINE LOAD

ENGINE FUELLING CORRECTION

ENGINE SPEED DROPS LESS



SHORTER SPEED RECOVERY

4.

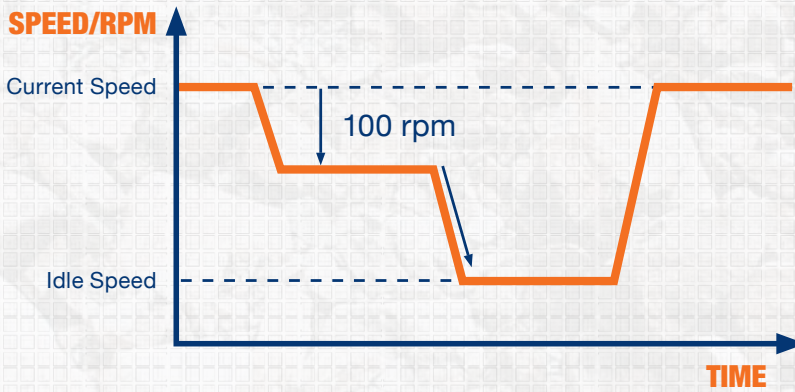

WHY COMPROMISE?

The all new FCR models let you do more, for less cost, and with less environmental impact, don't settle for anything less.



“ TOUGH MACHINES CAN BE INTELLIGENT TOO ”





INTELLIGENCE AND CONTROL

DESIGNED TO WORK SMARTER



DESIGNED TO WORK SMARTER

Smart operators choose smart machines because they know their job is tough enough. When it comes to intelligence and control the all New FCR models may surprise you as they're packed with smart features to make life easier.



INTELLIGENCE AND CONTROL

1. CHOOSE YOUR MODE

With a choice of 3 Integrated Work Modes each designed to match the engine speed, pump flow and system pressure to your chosen application, it's easy to find the perfect balance of performance and economy.

2. ELECTRO-HYDRAULIC CONTROL

The state-of-the-art full electro-hydraulic system from Kawasaki provides lightening fast signals between the joysticks, pumps and valve blocks to deliver pin point precision and maximize available engine power.

3. USE OUR BRAINS

With a suite of Smart functions at your fingertips you can control your attachment properties from the comfort of your cab. It's easy:

- Adjustable flow control
- Adjustable pressure control
- 10 attachment settings

4. LARGER HYDRAULIC PUMP

We've increased the size of our hydraulic pump with 12% greater displacement to increase flow at lower engine speeds and save on fuel.

5. TWO PIECE BOOM OPTION

915FCR EXTRA

Two piece boom option increases versatility with 300mm extra digging reach and flat bottom trench depth, plus 600mm increased dump height.

PERFORMANCE STATISTICS

1.

x3

DEDICATED POWER MODES

3.



INCREASED VERSITILITY

2.

+12%

INCREASE IN PUMP DISPLACEMENT

4.

x10

ATTACHMENT SETTINGS

1.



ECONOMY (E) MODE
FOR LIGHT WORK



STANDARD (S) MODE
FOR STANDARD OPERATION



POWER (P) MODE
FOR HEAVY DUTY

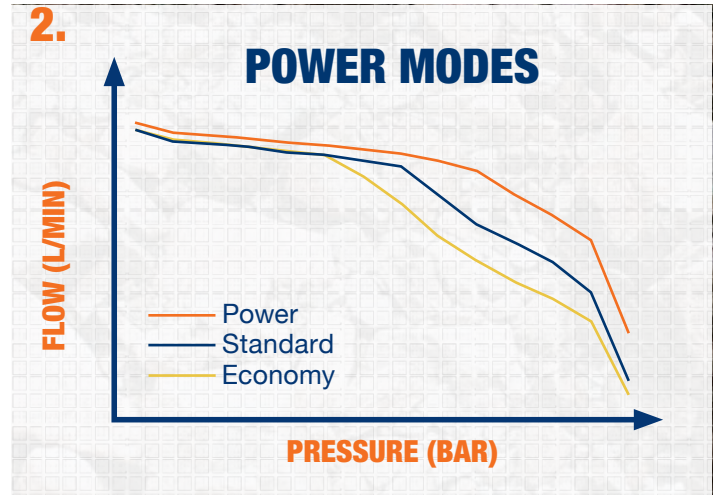

SMART IDEAS IN ACTION

The all New FCR models have the perfect balance of toughness and intelligence designed to keep you in control.



**TOUGH DAYS GO FASTER
YOU'RE WORKING IN COMFO**





**WHEN
RT ”**

UGONG

COMFORT AND ERGONOMICS

DESIGNED AROUND THE OPERATOR



DESIGNED AROUND THE OPERATOR

Climb into the spacious cab and you'll know that it has been designed by a team that really knows what its like to be an operator. Talking, listening and observing operators, our design team spend almost as much time in the cab as they do with the CAD. The result? One of the most ergonomic and comfortable cabs you can get.



COMFORT AND ERGONOMICS

1. PERFECT CONTROL

- From the ergonomically positioned non-slip pedals to the multi-functional joysticks, the cab interior represents a masterclass in design.
- Every action and movement requires the minimum of effort from the operator.

2. YOUR CHOICE OF SEAT

Every operator is different, so we offer a range of seats and joystick configurations to suit everyone.

- Mechanical suspension standard seat
- Comfort level, air suspension seat with adjustable lumbar support.
- Luxury level, heated air suspension seat with adjustable lumbar and premium padding.

2. IT'S SO QUIET

The cab is packed with comfort-enhancing technology; the NVH design reduces wind resistance and noise, and the silicone oil shock absorbers and CAE analysis all add up to the calmest and quietest operator experience possible.

3. INTUITIVE INTERFACE

We've designed the operator interface to be even more intuitive and easy to use. The large 8-inch LCD colour screen can be controlled via touchscreen or by a fingertip navigational control dial conveniently sited in the armrest control panel.

2. MAKE IT YOUR PLACE

We never forget that a machine is not just a tool, it's your place for many hours a day (and night). So, we've remembered all the little things that make it feel like home.

- Large storage box and rack
- Drinks holder
- Phone holder with 12V charging, USB and AUX ports

TICKS ALL THE RIGHT BOXES

INTUITIVE LCD OPERATOR CONSOLE

ERGONOMIC LAYOUT

FULLY PRESSURIZED (100PA)

ADVANCE AIR-CON AND TEMPERATURE CONTROL

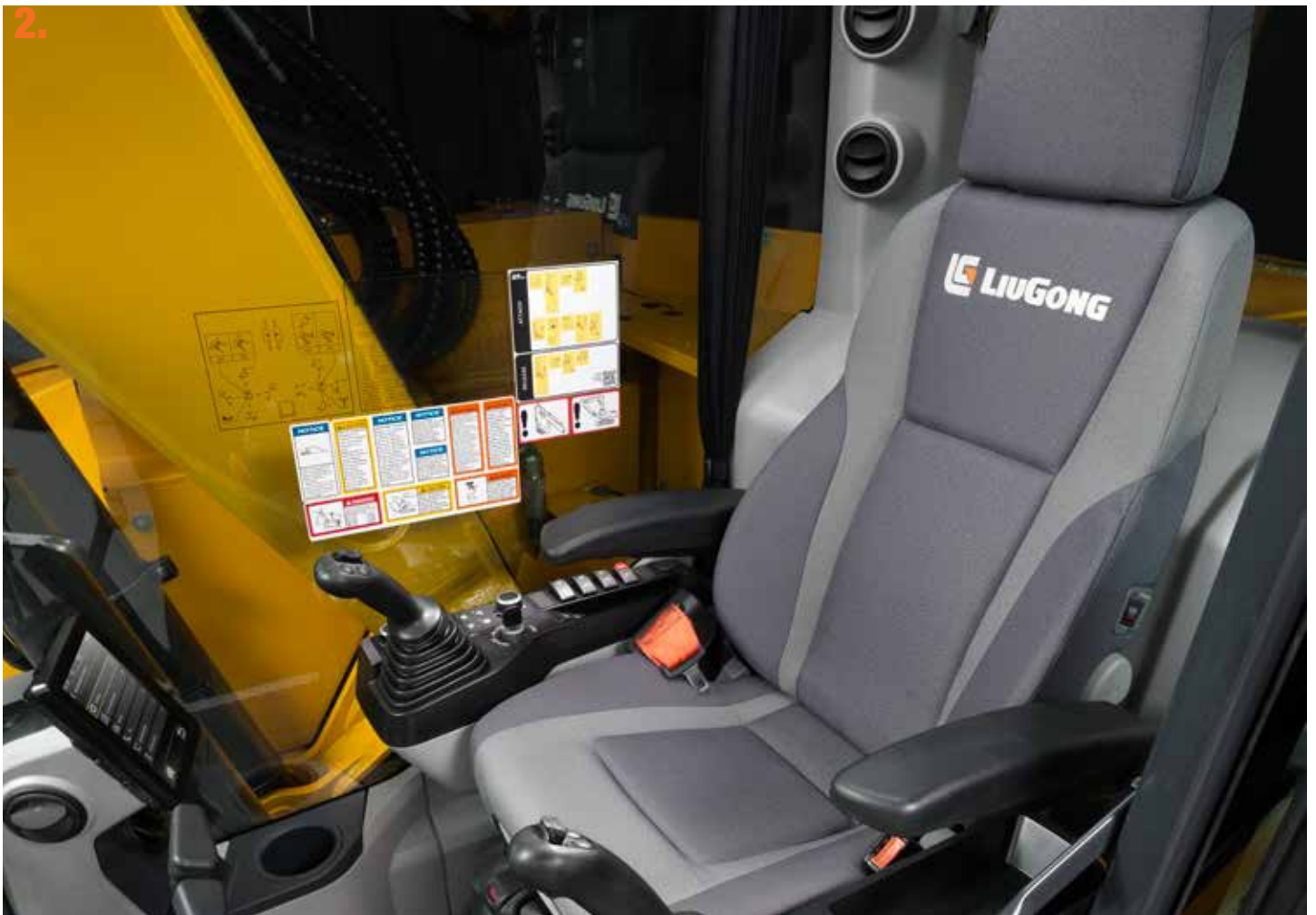

PERFECTLY MATCHED TO YOU

The all New FCR models gives you the operating environment you would design for yourself.

ENHANCED VISIBILITY

CUSTOMIZABLE OPERATING HANDLE

HIGH COMFORT, FULLY ADJUSTABLE SEAT

LOW NOISE AND LOW VIBRATION

**“ WE CONSTANTLY ASK...
MAKE OUR MACHINES EVEN**





HOW CAN WE SAFER ”



SAFETY AND VISIBILITY

DESIGNED TO PROTECT



SAFER ALL-ROUND

Being protected in the cab is important, but accident research shows us that most accidents occur outside of the machine. We've taken the challenge to make our machines even safer to be around.



SAFETY AND VISIBILITY

1. MORE PROTECTION WHERE YOU NEED IT

The driver protection system delivers even greater protection to the front and top of the cab and protects the operator from falling rocks and debris. The front screen has a hinge design making cleaning and maintenance easier.

2. WATCH YOUR STEP

- ▶ The new 0.5m wide stepped boarding channel with non-slip treadplates makes getting on and off the machine safer
- ▶ Optional guard rails or integral fences on the left and right sides of the upper platform increase safety and can be folded down for easy transportation.

3. EMERGENCY STOP

The ground level emergency stop switch is fitted as standard.

4. NO BLIND SPOTS

With 360 degree camera as standard in Europe, you can get an uninterrupted panoramic view around the machine at all angles from the large LCD screen.

5. SAFER AND MORE VERSATILE

- ▶ With a 1.52m tail swing, our new FCR models can work in the tightest of spaces.
- ▶ Shorter tail swing reduces potential collision damage.
- ▶ Creates a safer environment for those working around the machine.

6. SAFER MAINTENANCE ACCESS

No need to climb on the machine, all the daily maintenance points, including the oil level check point are easily accessible from the ground.

7. BE SAFE. BE SEEN

LED work light for better night visibility is fitted as standard.

BETTER BY DESIGN

LiuGong's Red Dot Award winning design* team is rapidly building a reputation for un-matched visibility. When you can see more you can do more, whilst protecting yourself and people around the machine.

With the All New FCR models we've pushed the barriers and taken visibility another step forward.

*4180D Motorgrader

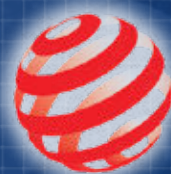

reddot design award



YOUR SAFETY - OUR PRIORITY

The all New FCR models have the perfect balance toughness and intelligence designed to keep you in control.

“ CAN DAILY MAINTENANCE
AS SIMPLE AS THIS? ”





E REALLY BE



UPTIME AND MAINTENANCE

DESIGNED TO BE EASY TO SERVICE AND MAINTAIN



EASY TO OWN AND EASY TO MAINTAIN

We understand that when your machine's not working, it's not earning. To maximize your productive hours, we've made the All New FCR models are even easier to maintain, helping you make every productive second count.



MAINTENANCE AND UPTIME

1. FULLY SYNCHRONIZED MAINTENANCE

Maintenance should be simple so to save you time, all engine oil filter replacement cycles have been synchronized.

2. MAINTENANCE FRIENDLY DESIGN

Our aim was to maximise uptime by making service and maintenance as convenient as possible. Our design team rose to the challenge delivering service and maintenance layout which is second to none.

3. NO RISK - LOW LEVEL ACCESS

Convenience and safety should never be compromised.

- The easy to access optional re-fuelling pump is safely stowed behind the bay door.
- All filters are located close to the bay doors for safe access and speedy maintenance.
- Low level access to DEF tank reduces the need to climb up onto the upper structure.

4. MAKING IT FASTER EVERYDAY

By grouping the greasing points together on the boom base, top of the dipper and slew bearing we make daily maintenance faster and easier.

5. 1000H MAINTENANCE CYCLE

Our red-designed air filter with large ash capacity now has a 1000-hour maintenance cycle – that's one job less to think about.

6. NO RUST, GREATER CAPACITY

Our plastic moulded fuel tank increases fuel capacity and will never rust, preventing filter blockage.

PERFORMANCE STATISTICS

1. **500mm**
WIDE ACCESS STEPS

5. **1000 hour**
AIR FILTER LIFE

5. **+14%**
FINER FUEL FILTER ELEMENTS

3. **GROUND LEVEL MAINTENANCE**



SPECIFICATIONS 913F_{CR}

Operating weight	14,700-16,500 kg (32,408-36,376 lbs)
-------------------------	---

Operating weight includes coolant, lubricants, full fuel tank, cab, standard shoes, boom, arm, bucket and operator 75 kg.

Bucket capacity	0.36 - 0.73 m³ (0.47-0.95 yd³)
------------------------	---

ENGINE

Description

Cummins EU Stage V, turbocharged, 4 cylinder, 4 stroke, water cooled

Emission rating	EU Stage V
-----------------	------------

Engine manufacturer	Cummins
---------------------	---------

Engine model	F3.8
--------------	------

Displacement	3.8 L (1 gal)
--------------	---------------

Rated speed	2,200 rpm
-------------	-----------

Engine Output - Net (SAE J1349 / ISO 9249)	69.5 kW (93.2 hp / 94.5 ps)
--	-----------------------------

Engine Output - Gross (SAE J1995 / ISO 14396)	75 kW (100.6 hp / 101.9 ps)
---	-----------------------------

Maximum torque	500 N·m (369 lbf·ft) @1,500 rpm
----------------	---------------------------------

Bore × Stroke	102 × 115 mm (4" × 4.5")
---------------	--------------------------

UNDERCARRIAGE

Track shoe each side	44 (1.7")
----------------------	-----------

Link pitch	175 mm (6.9" metal)
------------	---------------------

Shoe width, triple grouser	500/600/700 mm (20"/24"/28")
----------------------------	------------------------------

Bottom rollers each side	7
--------------------------	---

Top rollers each side	1
-----------------------	---

SWING SYSTEM

Swing speed	11.3 rpm
-------------	----------

Swing torque	36,790 N·m (27,135 lbf·ft)
--------------	----------------------------

HYDRAULIC SYSTEM

Main pump

Type	Two variable displacement piston pumps
------	--

Maximum flow	2 x 117 L/min (2 x 30.9 gal/min)
--------------	----------------------------------

Relief valve setting

Implement	34.3 / 37 MPa (4,975 / 5,366 psi)
-----------	-----------------------------------

Travel circuit	34.3 MPa (4,975 psi)
----------------	----------------------

Slew circuit	26.5 MPa (3,843 psi)
--------------	----------------------

Pilot circuit	3.9 MPa (566 psi)
---------------	-------------------

Hydraulic cylinders

Boom Cylinder – Bore × Stroke	Φ105 × 1,000 mm (4.1"×3'3")
-------------------------------	-----------------------------

Arm Cylinder – Bore × Stroke	Φ115 × 1,175 mm (4.5"×3'10")
------------------------------	------------------------------

Bucket Cylinder – Bore × Stroke	Φ95 × 885 mm (3.7"×2'11")
---------------------------------	---------------------------

ELECTRIC SYSTEM

System voltage	12 V
----------------	------

Batteries	2x12 V
-----------	--------

Alternator	12 V - 70 A
------------	-------------

Start motor	12 V - 4.8 kW (24 V - 6.4 hp)
-------------	-------------------------------

SERVICE CAPACITIES

Fuel tank	200 L (52.8 gal)
-----------	------------------

Engine oil	12 L (3.2 gal)
------------	----------------

Final drive (each)	2.5 L (0.7 gal)
--------------------	-----------------

Swing drive	3 L (0.8 gal)
-------------	---------------

Cooling system	20 L (5.3 gal)
----------------	----------------

Hydraulic reservoir	100 L (26.4 gal)
---------------------	------------------

Hydraulic system total	160 L (42.3 gal)
------------------------	------------------

DEF tank	25 L (6.6 gal)
----------	----------------

SOUND PERFORMANCE

Interior Sound Power Level (ISO 6396)	72 dB(A)
---------------------------------------	----------

Exterior Sound Power Level (ISO 6395)	99 dB(A)
---------------------------------------	----------

DRIVE AND BRAKES

Description

Steering controlled by two hand levers with pedals.

Max. travel speed	High: 4.9 km/h (3 mph) Low: 2.9 km/h (1.8 mph)
-------------------	---

Gradeability	35°/70%
--------------	---------

Max. drawbar pull	122 kN (27,427 lbf)
-------------------	---------------------



DIMENSIONS

Boom	4,600 mm	
Arm Options	2,500 mm	2,900 mm
A Shipping Length	7,295 mm	7,260 mm
B Shipping Height	2,980 mm	3,190 mm
C Undercarriage Width - 500 mm (20") shoes	2,490 mm	
600 mm (24") shoes	2,590 mm	
700 mm (28") shoes	2,690 mm	
D Shipping Length on Ground	4,435 mm	4,255 mm
E Track Gauge	1,990 mm	
F Length to Center of Rollers	2,930 mm	
G Track Length	3,660 mm	
H Overall Width of Upper Structure	2,490 mm	
J Overall Width of Upper Structure including Cab Handrail	2,570 mm	
K Overall Width of Upper Structure including Cab Rearview Mirror	2,790 mm	
L Tail Swing Radius	1,525 mm	
M Distance of Swing Center to Blade	2,805 mm	
N Counterweight Ground Clearance	925 mm	
P Overall Height of Counterweight	2,205 mm	
Q Overall Height of Cab	2,875 mm	
Overall Height of Cab including Halo	3,020 mm	
Overall Height of Cab including FOP's Guard	3,010 mm	
R Overall Height of Platform Handrail	2,925 mm	
S Min. Ground Clearance	440 mm	
T Track Shoe Width	500 mm	
U Blade, max. lifting height	500 mm	
V Blade, max. digging depth	575 mm	

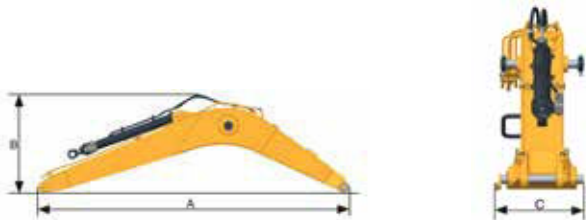

ARM DIMENSIONS

Arm	2,500 mm	2,900 mm
Length	3,300 mm	3,700 mm
Height	650 mm	700 mm
Width	450 mm	450 mm
Weight	640 kg	670 kg

Cylinder, linkage and pin included.



BOOM DIMENSIONS

Boom	/	
Length	4,800 mm	
Height	1,500 mm	
Width	750 mm	
Weight	1,170 kg	

Cylinder, piping and pin included. Boom cylinder pin excluded.

SPECIFICATIONS 913F_{CR}

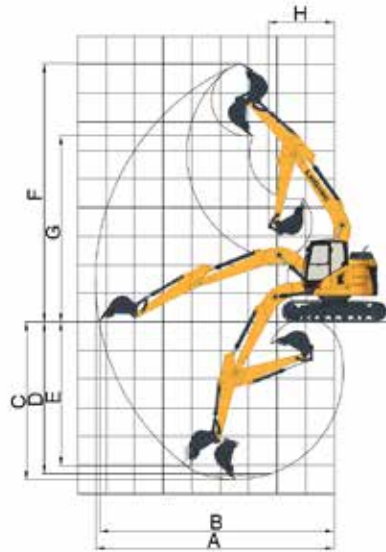

WORKING RANGE

MONO BOOM

Arm	2,500 mm	2,900 mm	
A. Max. Digging Reach	8,315 mm	8,705 mm	
B. Max. Digging Reach on Ground	8,190 mm	8,585 mm	
C. Max. Digging Depth	5,490 mm	5,890 mm	
D. Max. Digging Depth, 2.5m (8') Level	5,275 mm	5,700 mm	
E. Max. Vertical Wall Digging Depth	5,030 mm	5,415 mm	
F. Max. Cutting Height	8,960 mm	9,260 mm	
G. Max. Dumping Height	6,530 mm	6,835 mm	
H. Min. Front Swing Radius	2,325 mm	2,430 mm	
Bucket Digging Force (ISO)	Normal	89.8 kN	
	Power Boost	96.9 kN	
Arm Digging Force (ISO)	Normal	64.9 kN	58 kN
	Power Boost	70 kN	63.5 kN
Bucket Capacity	0.5 m ³		
Bucket Tip Radius	1,055 mm		

MACHINE WEIGHTS & GROUND PRESSURE

Shoe width	Operating weight	Ground pressure	Overall width
	Operating weight, including 2,500 mm arm, 450 kg bucket, additional weight with blade: +1,000 kg.		
500 mm	14,700 kg	44.9 kPa	2,490 mm
600 mm	14,900 kg	37.9 kPa	2,590 mm
700 mm	15,100 kg	32.9 kPa	2,690 mm
500 mm rubber crawler pads	14,700 kg	44.6 kPa	2,490 mm

BUCKET SELECTION GUIDE

Bucket type	Capacity	Cutting width	Weight	Teeth	4.6 m boom	
					2.5 m arm	2.9 m arm
Earth type	0.5 m ³	950 mm	450 kg	5 EA	B	B

The recommendations are given as a guide only, based on typical operation conditions.
Bucket capacity based on ISO 7451, heaped material with a 1:1 angle of repose.

Maximum material density:

- A. 1,200-1,300 kg/m³: Coal, Caliche, Shale
- B. 1,400-1,600 kg/m³: Wet earth and clay, limestone, sandstone
- C. 1,700-1,800 kg/m³: Granite, wet sand, well blasted rock
- D. 1,900 kg/m³: Wet mud, Iron ore
- NA. Not applicable

Lifting capacity at the arm end without bucket.
For lifting capacity including bucket, weight of the bucket or the bucket with quick coupler must be deducted from the lifting capacities.

Lifting capacities are based on the machine standing on a firm, uniform supporting surface.



Rating over-front (Cf)



Rating over-side (Cs)

1. Do not attempt to lift or hold any load that is greater than these rated values at their specified load radius and height. Weight of all accessories must be deducted from the above lifting capacities.
2. The rated loads are in compliance with ISO 10567 Hydraulic Excavator Lift Capacity Rating Standard. They do not exceed 87% of hydraulic lifting capacity or 75% tipping load.
3. Ratings at bucket lift hook.

4. Lifting capacities are based on machine standing on level, firm and uniform ground.
5. *Indicates the load is limited by hydraulic capacity rather than tipping capacity.
6. Operator should be fully acquainted with the Operator's and Maintenance Instructions before operating this machine and rules for the safe operation of equipment should be adhered to at all times.

LIFTING CAPACITY (METRIC)

913FCR with 500 mm Shoes, 4,600 mm Boom, 2,500 mm Arm

A: load radius
B: load point height
C: Lifting capacity rating
Cf: Rated loads over front
Cs: Rated loads over side

Conditions

Boom length: 4,600 mm
Arm length: 2,500 mm
Bucket: None
counterweight: 3,000 kg
Shoes: 500 mm triple grouser shoes
Blade: None

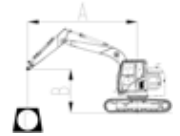

B/A (m)	1.5m		3.0m		4.5m		6m		MAX REACH			
	Cf	Cs	Cf	Cs	Cf	Cs	Cf	Cs	Cf	Cs	Distance	
6	kg				*3,600	*3,600			*2,050	*2,050	5.4	
4.5	kg				*3,800	3,600	*3,350	2,250	*2,350	2,100	6.3	
3	kg		*6,150	*6,150	*4,500	3,400	3,550	2,200	*1,950	1,750	6.9	
1.5	kg		*8,400	5,500	5,300	3,150	3,450	2,100	*2,550	1,650	7	
ground	kg		*7,200	5,150	5,100	2,950	3,350	2,000	*2,450	1,650	6.9	
-1.5	kg	*5,150	*5,150	*8,600	5,100	5,000	2,850	3,300	2,000	*2,800	1,850	6.4
-3	kg	*9,100	*9,100	*7,150	5,200	*4,900	2,900		*3,750	2,300	5.4	

LIFTING CAPACITY (METRIC)

913FCR with 600 mm Shoes, 4,600 mm Boom, 2,500 mm Arm

A: load radius
B: load point height
C: Lifting capacity rating
Cf: Rated loads over front
Cs: Rated loads over side

Conditions

Boom length: 4,600 mm
Arm length: 2,500 mm
Bucket: None
counterweight: 3,000 kg
Shoes: 600 mm triple grouser shoes
Blade: None

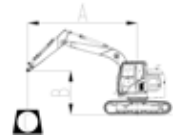

B/A (m)	1.5m		3.0m		4.5m		6m		MAX REACH			
	Cf	Cs	Cf	Cs	Cf	Cs	Cf	Cs	Cf	Cs	Distance	
6	kg				*3,600	*3,600			*2,050	*2,050	5.4	
4.5	kg				*3,800	3,650	*3,350	2,300	*2,350	2,100	6.3	
3	kg		*6,150	*6,150	*4,500	3,450	3,600	2,250	*1,950	1,800	6.9	
1.5	kg		*8,400	5,600	*5,350	3,200	3,500	2,150	*2,550	1,700	7	
ground	kg		*7,200	5,250	5,200	3,000	3,400	2,050	*2,450	1,700	6.9	
-1.5	kg	*5,150	*5,150	*8,600	5,200	5,100	2,950	3,350	2,000	*2,800	1,850	6.4
-3	kg	*9,100	*9,100	*7,150	5,300	*4,900	2,950		*3,750	2,350	5.4	

SPECIFICATIONS 913FCR

Lifting capacity at the arm end without bucket.

For lifting capacity including bucket, weight of the bucket or the bucket with quick coupler must be deducted from the lifting capacities.

Lifting capacities are based on the machine standing on a firm, uniform supporting surface.



Rating over-front (Cf)



Rating over-side (Cs)

1. Do not attempt to lift or hold any load that is greater than these rated values at their specified load radius and height. Weight of all accessories must be deducted from the above lifting capacities.
2. The rated loads are in compliance with ISO 10567 Hydraulic Excavator Lift Capacity Rating Standard. They do not exceed 87% of hydraulic lifting capacity or 75% tipping load.
3. Ratings at bucket lift hook.

4. Lifting capacities are based on machine standing on level, firm and uniform ground.
5. *Indicates the load is limited by hydraulic capacity rather than tipping capacity.
6. Operator should be fully acquainted with the Operator's and Maintenance Instructions before operating this machine and rules for the safe operation of equipment should be adhered to at all times.

LIFTING CAPACITY (METRIC)

913FCR with 700 mm Shoes, 4,600 mm Boom, 2,500 mm Arm

A: load radius
B: load point height
C: Lifting capacity rating
Cf: Rated loads over front
Cs: Rated loads over side

Conditions

Boom length: 4,600 mm
Arm length: 2,500 mm
Bucket: None
counterweight: 3,000 kg
Shoes: 700 mm triple grouser shoes
Blade: None

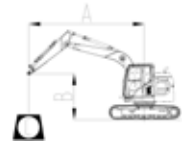

B/A (m)	1.5m		3.0m		4.5m		6m		MAX REACH			
	Cf	Cs	Cf	Cs	Cf	Cs	Cf	Cs	Cf	Cs	Distance	
6	kg				*3,600	*3,600			*2,050	*2,050	5.4	
4.5	kg				*3,800	3,700	*3,350	2,350	*2,350	2,150	6.3	
3	kg		*6,150	*6,150	*4,500	3,500	3,700	2,300	*1,950	1,850	6.9	
1.5	kg		*8,400	5,700	*5,350	3,250	3,550	2,200	*2,550	1,750	7	
ground	kg		*7,200	5,350	5,250	3,050	3,450	2,100	*2,450	1,750	6.9	
-1.5	kg	*5,150	*5,150	*8,600	5,300	5,200	3,000	3,450	2,050	*2,800	1,900	6.4
-3	kg	*9,100	*9,100	*7,150	5,400	*4,900	3,000		*3,750	2,400	5.4	

LIFTING CAPACITY (METRIC)

913FCR with 500 mm Rubber Shoes, 4,600 mm Boom, 2,500 mm Arm

A: load radius
B: load point height
C: Lifting capacity rating
Cf: Rated loads over front
Cs: Rated loads over side

Conditions

Boom length: 4,600 mm
Arm length: 2,500 mm
Bucket: None
counterweight: 3,000 kg
Shoes: 500 mm rubber track shoes
Blade: None

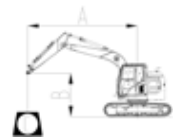

B/A (m)	1.5m		3.0m		4.5m		6m		MAX REACH			
	Cf	Cs	Cf	Cs	Cf	Cs	Cf	Cs	Cf	Cs	Distance	
6	kg				*3,600	*3,600			*2,050	*2,050	5.4	
4.5	kg				*3,800	3,600	*3,350	2,250	*2,350	2,050	6.3	
3	kg		*6,150	*6,150	*4,500	3,400	3,550	2,200	*1,950	1,750	6.9	
1.5	kg		*8,400	5,450	5,300	3,100	3,450	2,100	*2,550	1,650	7	
ground	kg		*7,200	5,150	5,050	2,950	3,350	2,000	*2,450	1,650	6.9	
-1.5	kg	*5,150	*5,150	*8,600	5,100	4,950	2,850	3,300	1,950	*2,800	1,800	6.4
-3	kg	*9,100	*9,100	*7,150	5,200	*4,900	2,900		*3,750	2,300	5.4	

Lifting capacity at the arm end without bucket.

For lifting capacity including bucket, weight of the bucket or the bucket with quick coupler must be deducted from the lifting capacities.

Lifting capacities are based on the machine standing on a firm, uniform supporting surface.



Rating over-front (Cf)



Rating over-side (Cs)

1. Do not attempt to lift or hold any load that is greater than these rated values at their specified load radius and height. Weight of all accessories must be deducted from the above lifting capacities.
2. The rated loads are in compliance with ISO 10567 Hydraulic Excavator Lift Capacity Rating Standard. They do not exceed 87% of hydraulic lifting capacity or 75% tipping load.
3. Ratings at bucket lift hook.

4. Lifting capacities are based on machine standing on level, firm and uniform ground.
5. *Indicates the load is limited by hydraulic capacity rather than tipping capacity.
6. Operator should be fully acquainted with the Operator's and Maintenance Instructions before operating this machine and rules for the safe operation of equipment should be adhered to at all times.

LIFTING CAPACITY (METRIC)

913FCR with 500 mm Shoes, 4,600 mm Boom, 2,900 mm Arm

A: load radius
B: load point height
C: Lifting capacity rating
Cf: Rated loads over front
Cs: Rated loads over side

Conditions

Boom length: 4,600 mm
Arm length: 2,900 mm
Bucket: None
counterweight: 3,000 kg
Shoes: 500 mm triple grouser shoes
Blade: None

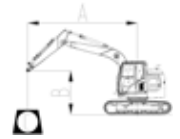

B/A (m)	1.5m		3.0m		4.5m		6m		MAX REACH			
	Cf	Cs	Cf	Cs	Cf	Cs	Cf	Cs	Cf	Cs	Distance	
6	kg				*3,200	*3,200			*1,700	*1,700	5.9	
4.5	kg				*3,450	*3,450	*3,350	2,300	*1,650	*1,650	6.8	
3	kg		*5,400	*5,400	*4,150	3,450	3,600	2,250	*1,600	*1,600	7.3	
1.5	kg		*7,850	5,650	*5,100	3,200	3,450	2,100	*2,000	1,550	7.4	
ground	kg		*7,800	5,200	5,100	2,950	3,350	2,000	*1,950	1,550	7.3	
-1.5	kg	*4,700	*4,700	*8,850	5,100	5,000	2,850	3,300	1,950	*2,450	1,650	6.8
-3	kg	*7,900	*7,900	*7,650	5,150	5,000	2,850			*3,300	2,050	5.9
-4.5	kg			*5,050	*5,050					*3,100	*3,100	4.4

LIFTING CAPACITY (METRIC)

913FCR with 600 mm Shoes, 4,600 mm Boom, 2,900 mm Arm

A: load radius
B: load point height
C: Lifting capacity rating
Cf: Rated loads over front
Cs: Rated loads over side

Conditions

Boom length: 4,600 mm
Arm length: 2,900 mm
Bucket: None
counterweight: 3,000 kg
Shoes: 600 mm triple grouser shoes
Blade: None

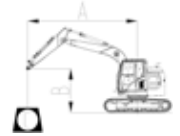

B/A (m)	1.5m		3.0m		4.5m		6m		MAX REACH			
	Cf	Cs	Cf	Cs	Cf	Cs	Cf	Cs	Cf	Cs	Distance	
6	kg				*3,200	*3,200			*1,700	*1,700	5.9	
4.5	kg				*3,450	*3,450	*3,350	2,350	*1,650	*1,650	6.8	
3	kg		*5,400	*5,400	*4,150	3,500	*3,600	2,300	*1,600	*1,600	7.3	
1.5	kg		*7,850	5,750	*5,100	3,250	3,550	2,150	*2,000	1,600	7.4	
ground	kg		*7,800	5,300	5,200	3,050	3,400	2,050	*1,950	1,550	7.3	
-1.5	kg	*4,700	*4,700	*8,850	5,200	5,100	2,900	3,350	2,000	*2,450	1,700	6.8
-3	kg	*7,900	*7,900	*7,650	5,250	5,100	2,950			*3,300	2,100	5.9
-4.5	kg			*5,050	*5,050					*3,100	*3,100	4.4

SPECIFICATIONS 913FCR

Lifting capacity at the arm end without bucket.
For lifting capacity including bucket, weight of the bucket or the bucket with quick coupler must be deducted from the lifting capacities.
Lifting capacities are based on the machine standing on a firm, uniform supporting surface.



Rating over-front (Cf)



Rating over-side (Cs)

- Do not attempt to lift or hold any load that is greater than these rated values at their specified load radius and height. Weight of all accessories must be deducted from the above lifting capacities.
- The rated loads are in compliance with ISO 10567 Hydraulic Excavator Lift Capacity Rating Standard. They do not exceed 87% of hydraulic lifting capacity or 75% tipping load.
- Ratings at bucket lift hook.

- Lifting capacities are based on machine standing on level, firm and uniform ground.
- *Indicates the load is limited by hydraulic capacity rather than tipping capacity.
- Operator should be fully acquainted with the Operator's and Maintenance Instructions before operating this machine and rules for the safe operation of equipment should be adhered to at all times.

LIFTING CAPACITY (METRIC)

913FCR with 700 mm Shoes, 4,600 mm Boom, 2,900 mm Arm

A: load radius
B: load point height
C: Lifting capacity rating
Cf: Rated loads over front
Cs: Rated loads over side

Conditions

Boom length: 4,600 mm
Arm length: 2,900 mm
Bucket: None
counterweight: 3,000 kg
Shoes: 700 mm triple grouser shoes
Blade: None

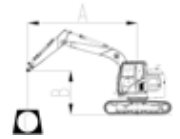

B/A (m)	1.5m		3.0m		4.5m		6m		MAX REACH			
	Cf	Cs	Cf	Cs	Cf	Cs	Cf	Cs	Cf	Cs	Distance	
6	kg				*3,200	*3,200			*1,700	*1,700	5.9	
4.5	kg				*3,450	*3,450	*3,350	2,400	*1,650	*1,650	6.8	
3	kg		*5,400	*5,400	*4,150	3,600	*3,600	2,300	*1,600	*1,600	7.3	
1.5	kg		*7,850	5,900	*5,100	3,300	3,600	2,200	*2,000	1,600	7.4	
ground	kg		*7,800	5,400	5,300	3,100	3,500	2,100	*1,950	1,600	7.3	
-1.5	kg	*4,700	*4,700	*8,850	5,300	5,200	3,000	3,400	2,050	*2,450	1,750	6.8
-3	kg	*7,900	*7,900	*7,650	5,350	5,200	3,000			*3,300	2,100	5.9
-4.5	kg			*5,050	*5,050					*3,100	*3,100	4.4

LIFTING CAPACITY (METRIC)

913FCR with 500 mm Rubber Shoes, 4,600 mm Boom, 2,900 mm Arm

A: load radius
B: load point height
C: Lifting capacity rating
Cf: Rated loads over front
Cs: Rated loads over side

Conditions

Boom length: 4,600 mm
Arm length: 2,900 mm
Bucket: None
counterweight: 3,000 kg
Shoes: 500 mm rubber track shoes
Blade: None

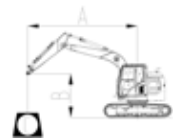

B/A (m)	1.5m		3.0m		4.5m		6m		MAX REACH			
	Cf	Cs	Cf	Cs	Cf	Cs	Cf	Cs	Cf	Cs	Distance	
6	kg				*3,200	*3,200			*1,700	*1,700	5.9	
4.5	kg				*3,450	*3,450	*3,350	2,300	*1,650	*1,650	6.8	
3	kg		*5,400	*5,400	*4,150	3,450	3,600	2,250	*1,600	*1,600	7.3	
1.5	kg		*7,850	5,650	*5,100	3,150	3,450	2,100	*2,000	1,550	7.4	
ground	kg		*7,800	5,200	5,100	2,950	3,350	2,000	*1,950	1,550	7.3	
-1.5	kg	*4,700	*4,700	*8,850	5,050	4,950	2,850	3,300	1,950	*2,450	1,650	6.8
-3	kg	*7,900	*7,900	*7,650	5,100	5,000	2,850			*3,300	2,000	5.9
-4.5	kg			*5,050	*5,050					*3,100	*3,100	4.4

Lifting capacity at the arm end without bucket.
For lifting capacity including bucket, weight of the bucket or the bucket with quick coupler must be deducted from the lifting capacities.
Lifting capacities are based on the machine standing on a firm, uniform supporting surface.



Rating over-front (Cf)



Rating over-side (Cs)

1. Do not attempt to lift or hold any load that is greater than these rated values at their specified load radius and height. Weight of all accessories must be deducted from the above lifting capacities.
2. The rated loads are in compliance with ISO 10567 Hydraulic Excavator Lift Capacity Rating Standard. They do not exceed 87% of hydraulic lifting capacity or 75% tipping load.
3. Ratings at bucket lift hook.
4. Lifting capacities are based on machine standing on level, firm and uniform ground.
5. *Indicates the load is limited by hydraulic capacity rather than tipping capacity.
6. Operator should be fully acquainted with the Operator's and Maintenance Instructions before operating this machine and rules for the safe operation of equipment should be adhered to at all times.

LIFTING CAPACITY (METRIC)

913FCR with 500 mm Shoes, 4,600 mm Boom, 2,500 mm Arm

A: load radius
B: load point height
C: Lifting capacity rating
Cf: Rated loads over front
Cs: Rated loads over side

Conditions

Boom length: 4,600 mm
Arm length: 2,500 mm
Bucket: None
counterweight: 3,000 kg
Shoes: 500 mm triple grouser shoes
Blade: YES

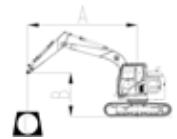

Blade Down

B/A (m)	1.5m		3.0m		4.5m		6m		MAX REACH			
	Cf	Cs	Cf	Cs	Cf	Cs	Cf	Cs	Cf	Cs	Distance	
6	kg				*3,600	3,600			*2,050	*2,050	5.4	
4.5	kg				*3,800	3,550	*3,350	2,200	*2,350	2,050	6.3	
3	kg		*6,150	*6,150	*4,500	3,300	*3,800	2,150	*1,950	1,700	6.9	
1.5	kg		*8,400	5,350	*5,350	3,050	*4,150	2,050	*2,550	1,650	7	
ground	kg		*7,200	5,050	*5,850	2,850	*4,350	1,950	*2,450	1,600	6.9	
-1.5	kg	*5,150	*5,150	*8,600	5,000	*5,800	2,800	*4,200	1,950	*2,800	1,800	6.4
-3	kg	*9,100	*9,100	*7,150	5,100	*4,900	2,850		*3,750	2,250	5.4	

Blade Up

B/A (m)	1.5m		3.0m		4.5m		6m		MAX REACH			
	Cf	Cs	Cf	Cs	Cf	Cs	Cf	Cs	Cf	Cs	Distance	
6	kg				*3,600	3,600			*2,050	*2,050	5.4	
4.5	kg				*3,800	3,550	*3,350	2,200	*2,350	2,050	6.3	
3	kg		*6,150	*6,150	*4,500	3,300	3,600	2,150	*1,950	1,700	6.9	
1.5	kg		*8,400	5,350	5,350	3,050	3,450	2,050	*2,550	1,650	7	
ground	kg		*7,200	5,050	5,100	2,850	3,350	1,950	*2,450	1,600	6.9	
-1.5	kg	*5,150	*5,150	*8,600	5,000	5,000	2,800	3,300	1,950	*2,800	1,800	6.4
-3	kg	*9,100	*9,100	*7,150	5,100	*4,900	2,850		*3,750	2,250	5.4	

SPECIFICATIONS 913FCR

Lifting capacity at the arm end without bucket.
For lifting capacity including bucket, weight of the bucket or the bucket with quick coupler must be deducted from the lifting capacities.

Lifting capacities are based on the machine standing on a firm, uniform supporting surface.



Rating over-front (Cf)



Rating over-side (Cs)

- Do not attempt to lift or hold any load that is greater than these rated values at their specified load radius and height. Weight of all accessories must be deducted from the above lifting capacities.
- The rated loads are in compliance with ISO 10567 Hydraulic Excavator Lift Capacity Rating Standard. They do not exceed 87% of hydraulic lifting capacity or 75% tipping load.
- Ratings at bucket lift hook.

- Lifting capacities are based on machine standing on level, firm and uniform ground.
- *Indicates the load is limited by hydraulic capacity rather than tipping capacity.
- Operator should be fully acquainted with the Operator's and Maintenance Instructions before operating this machine and rules for the safe operation of equipment should be adhered to at all times.

LIFTING CAPACITY (METRIC)

913FCR with 600 mm Shoes, 4,600 mm Boom, 2,500 mm Arm

A: load radius
B: load point height
C: Lifting capacity rating
Cf: Rated loads over front
Cs: Rated loads over side

Conditions

Boom length: 4,600 mm
Arm length: 2,500 mm
Bucket: None
counterweight: 3,000 kg
Shoes: 600 mm triple grouser shoes
Blade: YES

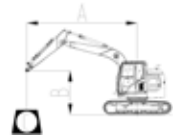

Blade Down

B/A (m)	1.5m		3.0m		4.5m		6m		MAX REACH			
	Cf	Cs	Cf	Cs	Cf	Cs	Cf	Cs	Cf	Cs	Distance	
6	kg				*3,600	*3,600			*2,050	*2,050	5.4	
4.5	kg				*3,800	3,600	*3,350	2,250	*2,350	2,050	6.3	
3	kg		*6,150	*6,150	*4,500	3,400	*3,800	2,200	*1,950	1,750	6.9	
1.5	kg		*8,400	5,450	*5,350	3,100	*4,150	2,100	*2,550	1,650	7	
ground	kg		*7,200	5,100	*5,850	2,950	*4,350	2,000	*2,450	1,650	6.9	
-1.5	kg	*5,150	*5,150	*8,600	5,050	*5,800	2,850	*4,200	1,950	*2,800	1,800	6.4
-3	kg	*9,100	*9,100	*7,150	5,150	*4,900	2,900		*3,750	2,300	5.4	

Blade Up

B/A (m)	1.5m		3.0m		4.5m		6m		MAX REACH			
	Cf	Cs	Cf	Cs	Cf	Cs	Cf	Cs	Cf	Cs	Distance	
6	kg				*3,600	*3,600			*2,050	*2,050	5.4	
4.5	kg				*3,800	3,600	*3,350	2,250	*2,350	2,050	6.3	
3	kg		*6,150	*6,150	*4,500	3,400	3,650	2,200	*1,950	1,750	6.9	
1.5	kg		*8,400	5,450	*5,350	3,100	3,500	2,100	*2,550	1,650	7	
ground	kg		*7,200	5,100	5,200	2,950	3,400	2,000	*2,450	1,650	6.9	
-1.5	kg	*5,150	*5,150	*8,600	5,050	5,100	2,850	3,400	1,950	*2,800	1,800	6.4
-3	kg	*9,100	*9,100	*7,150	5,150	*4,900	2,900		*3,750	2,300	5.4	

Lifting capacity at the arm end without bucket.
For lifting capacity including bucket, weight of the bucket or the bucket with quick coupler must be deducted from the lifting capacities.

Lifting capacities are based on the machine standing on a firm, uniform supporting surface.



Rating over-front (Cf)



Rating over-side (Cs)

1. Do not attempt to lift or hold any load that is greater than these rated values at their specified load radius and height. Weight of all accessories must be deducted from the above lifting capacities.
2. The rated loads are in compliance with ISO 10567 Hydraulic Excavator Lift Capacity Rating Standard. They do not exceed 87% of hydraulic lifting capacity or 75% tipping load.
3. Ratings at bucket lift hook.

4. Lifting capacities are based on machine standing on level, firm and uniform ground.
5. *Indicates the load is limited by hydraulic capacity rather than tipping capacity.
6. Operator should be fully acquainted with the Operator's and Maintenance Instructions before operating this machine and rules for the safe operation of equipment should be adhered to at all times.

LIFTING CAPACITY (METRIC)

913FCR with 700 mm Shoes, 4,600 mm Boom, 2,500 mm Arm

A: load radius
B: load point height
C: Lifting capacity rating
Cf: Rated loads over front
Cs: Rated loads over side

Conditions

Boom length: 4,600 mm
Arm length: 2,500 mm
Bucket: None
counterweight: 3,000 kg
Shoes: 700 mm triple grouser shoes
Blade: YES

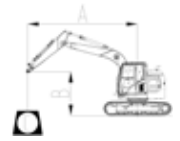

Blade Down

B/A (m)		1.5m		3.0m		4.5m		6m		MAX REACH		
		Cf	Cs	Cf	Cs	Cf	Cs	Cf	Cs	Cf	Cs	Distance
6	kg					*3,600	*3,600			*2,050	*2,050	5.4
4.5	kg					*3,800	3,650	*3,350	2,300	*2,350	2,100	6.3
3	kg			*6,150	*6,150	*4,500	3,450	*3,800	2,250	*1,950	1,800	6.9
1.5	kg			*8,400	5,550	*5,350	3,150	*4,150	2,150	*2,550	1,700	7
ground	kg			*7,200	5,200	*5,850	3,000	*4,350	2,050	*2,450	1,700	6.9
-1.5	kg	*5,150	*5,150	*8,600	5,150	*5,800	2,900	*4,200	2,000	*2,800	1,850	6.4
-3	kg	*9,100	*9,100	*7,150	5,250	*4,900	2,950			*3,750	2,350	5.4

Blade Up

B/A (m)		1.5m		3.0m		4.5m		6m		MAX REACH		
		Cf	Cs	Cf	Cs	Cf	Cs	Cf	Cs	Cf	Cs	Distance
6	kg					*3,600	*3,600			*2,050	*2,050	5.4
4.5	kg					*3,800	3,650	*3350	2,300	*2,350	2,100	6.3
3	kg			*6,150	*6,150	*4,500	3,450	3,700	2,250	*1,950	1,800	6.9
1.5	kg			*8,400	5,550	*5,350	3,150	3,600	2,150	*2,550	1,700	7
ground	kg			*7,200	5,200	5,300	3,000	3,500	2,050	*2,450	1,700	6.9
-1.5	kg	*5,150	*5,150	*8,600	5,150	5,200	2,900	3,450	2,000	*2,800	1,850	6.4
-3	kg	*9,100	*9,100	*7,150	5,250	*4,900	2,950			*3,750	2,350	5.4

SPECIFICATIONS 913FCR

Lifting capacity at the arm end without bucket.
For lifting capacity including bucket, weight of the bucket or the bucket with quick coupler must be deducted from the lifting capacities.
Lifting capacities are based on the machine standing on a firm, uniform supporting surface.



Rating over-front (Cf)



Rating over-side (Cs)

- Do not attempt to lift or hold any load that is greater than these rated values at their specified load radius and height. Weight of all accessories must be deducted from the above lifting capacities.
- The rated loads are in compliance with ISO 10567 Hydraulic Excavator Lift Capacity Rating Standard. They do not exceed 87% of hydraulic lifting capacity or 75% tipping load.
- Ratings at bucket lift hook.
- Lifting capacities are based on machine standing on level, firm and uniform ground.
- *Indicates the load is limited by hydraulic capacity rather than tipping capacity.
- Operator should be fully acquainted with the Operator's and Maintenance Instructions before operating this machine and rules for the safe operation of equipment should be adhered to at all times.

LIFTING CAPACITY (METRIC)

913FCR with 500 mm Rubber Shoes, 4,600 mm Boom, 2,500 mm Arm

Conditions

A: load radius
B: load point height
C: Lifting capacity rating
Cf: Rated loads over front
Cs: Rated loads over side

Boom length: 4,600 mm
Arm length: 2,500 mm
Bucket: None
counterweight: 3,000 kg
Shoes: 500 mm rubber track shoes
Blade: YES

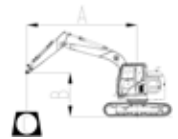

Blade Down

B/A (m)	1.5m		3.0m		4.5m		6m		MAX REACH			
	Cf	Cs	Cf	Cs	Cf	Cs	Cf	Cs	Cf	Cs	Distance	
6	kg				*3,600	3,600			*2,050	*2,050	5.4	
4.5	kg				*3,800	3,500	*3,350	2,200	*2,350	2,050	6.3	
3	kg		*6,150	6,100	*4,500	3,300	*3,800	2,150	*1,950	1,700	6.9	
1.5	kg		*8,400	5,350	*5,350	3,050	*4,150	2,050	*2,550	1,600	7	
ground	kg		*7,200	5,000	*5,850	2,850	*4,350	1,950	*2,450	1,600	6.9	
-1.5	kg	*5,150	*5,150	*8,600	4,950	*5,800	2,800	*4,200	1,900	*2,800	1,750	6.4
-3	kg	*9,100	*9,100	*7,150	5,050	*4,900	2,800		*3,750	2,250	5.4	

Blade Up

B/A (m)	1.5m		3.0m		4.5m		6m		MAX REACH			
	Cf	Cs	Cf	Cs	Cf	Cs	Cf	Cs	Cf	Cs	Distance	
6	kg				*3,600	3,600			*2,050	*2,050	5.4	
4.5	kg				*3,800	3,500	*3,350	2,200	*2,350	2,050	6.3	
3	kg		*6,150	6,100	*4,500	3,300	3,550	2,150	*1,950	1,700	6.9	
1.5	kg		*8,400	5,350	5,300	3,050	3,450	2,050	*2,550	1,600	7	
ground	kg		*7,200	5,000	5,100	2,850	3,350	1,950	*2,450	1,600	6.9	
-1.5	kg	*5,150	*5,150	*8,600	4,950	5,000	2,800	3,300	1,900	*2,800	1,750	6.4
-3	kg	*9,100	*9,100	*7,150	5,050	*4,900	2,800		*3,750	2,250	5.4	

Lifting capacity at the arm end without bucket.
For lifting capacity including bucket, weight of the bucket or the bucket with quick coupler must be deducted from the lifting capacities.
Lifting capacities are based on the machine standing on a firm, uniform supporting surface.



Rating over-front (Cf)



Rating over-side (Cs)

1. Do not attempt to lift or hold any load that is greater than these rated values at their specified load radius and height. Weight of all accessories must be deducted from the above lifting capacities.
2. The rated loads are in compliance with ISO 10567 Hydraulic Excavator Lift Capacity Rating Standard. They do not exceed 87% of hydraulic lifting capacity or 75% tipping load.
3. Ratings at bucket lift hook.

4. Lifting capacities are based on machine standing on level, firm and uniform ground.
5. *Indicates the load is limited by hydraulic capacity rather than tipping capacity.
6. Operator should be fully acquainted with the Operator's and Maintenance Instructions before operating this machine and rules for the safe operation of equipment should be adhered to at all times.

LIFTING CAPACITY (METRIC)

913FCR with 500 mm Shoes, 4,600 mm Boom, 2,900 mm Arm

A: load radius
B: load point height
C: Lifting capacity rating
Cf: Rated loads over front
Cs: Rated loads over side

Conditions

Boom length: 4,600 mm
Arm length: 2,900 mm
Bucket: None
counterweight: 3,000 kg
Shoes: 500 mm triple grouser shoes
Blade: YES

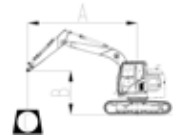

Blade Down

B/A (m)	1.5m		3.0m		4.5m		6m		MAX REACH			
	Cf	Cs	Cf	Cs	Cf	Cs	Cf	Cs	Cf	Cs	Distance	
6	kg				*3,200	*3,200			*1,700	*1,700	5.9	
4.5	kg				*3,450	*3,450	*3,350	2,250	*1,650	*1,650	6.8	
3	kg		*5,400	*5,400	*4,150	3,400	*3,600	2,200	*1,600	1,600	7.3	
1.5	kg		*7,850	5,550	*5,100	3,100	*4,000	2,050	*2,000	1,500	7.4	
ground	kg		*7,800	5,050	*5,750	2,900	*4,300	1,950	*1,950	1,500	7.3	
-1.5	kg	*4,700	*4,700	*8,850	4,950	*5,850	2,800	*4,250	1,900	*2,450	1,600	6.8
-3	kg	*7,900	*7,900	*7,650	5,000	*5,250	2,800		*3,300	2,000	5.9	
-4.5	kg		*5,050	*5,050					*3,100	3,050	4.4	

Blade Up

B/A (m)	1.5m		3.0m		4.5m		6m		MAX REACH			
	Cf	Cs	Cf	Cs	Cf	Cs	Cf	Cs	Cf	Cs	Distance	
6	kg				*3,200	*3,200			*1,700	*1,700	5.9	
4.5	kg				*3,450	*3,450	*3,350	2,250	*1,650	*1,650	6.8	
3	kg		*5,400	*5,400	*4,150	3,400	*3,600	2,200	*1,600	1,600	7.3	
1.5	kg		*7,850	5,550	*5,100	3,100	3,500	2,050	*2,000	1,500	7.4	
ground	kg		*7,800	5,050	5,150	2,900	3,350	1,950	*1,950	1,500	7.3	
-1.5	kg	*4,700	*4,700	*8,850	4,950	5,000	2,800	3,300	1,900	*2,450	1,600	6.8
-3	kg	*7,900	*7,900	*7,650	5,000	5,000	2,800		*3,300	2,000	5.9	
-4.5	kg		*5,050	*5,050					*3,100	3,050	4.4	

SPECIFICATIONS 913FCR

Lifting capacity at the arm end without bucket.
For lifting capacity including bucket, weight of the bucket or the bucket with quick coupler must be deducted from the lifting capacities.
Lifting capacities are based on the machine standing on a firm, uniform supporting surface.



Rating over-front (Cf)



Rating over-side (Cs)

1. Do not attempt to lift or hold any load that is greater than these rated values at their specified load radius and height. Weight of all accessories must be deducted from the above lifting capacities.
2. The rated loads are in compliance with ISO 10567 Hydraulic Excavator Lift Capacity Rating Standard. They do not exceed 87% of hydraulic lifting capacity or 75% tipping load.
3. Ratings at bucket lift hook.

4. Lifting capacities are based on machine standing on level, firm and uniform ground.
5. *Indicates the load is limited by hydraulic capacity rather than tipping capacity.
6. Operator should be fully acquainted with the Operator's and Maintenance Instructions before operating this machine and rules for the safe operation of equipment should be adhered to at all times.

LIFTING CAPACITY (METRIC)

913FCR with 600 mm Shoes, 4,600 mm Boom, 2,900 mm Arm

A: load radius
B: load point height
C: Lifting capacity rating
Cf: Rated loads over front
Cs: Rated loads over side

Conditions

Boom length: 4,600 mm
Arm length: 2,900 mm
Bucket: None
counterweight: 3,000 kg
Shoes: 600 mm triple grouser shoes
Blade: YES

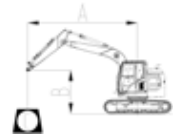

Blade Down

B/A (m)		1.5m		3.0m		4.5m		6m		MAX REACH		
		Cf	Cs	Cf	Cs	Cf	Cs	Cf	Cs	Cf	Cs	Distance
6	kg					*3,200	*3,200			*1,700	*1,700	5.9
4.5	kg					*3,450	*3,450	*3,350	2,300	*1,650	*1,650	6.8
3	kg			*5,400	*5,400	*4,150	3,450	*3,600	2,200	*1,600	*1,600	7.3
1.5	kg			*7,850	5,600	*5,100	3,150	*4,000	2,100	*2,000	1,550	7.4
ground	kg			*7,800	5,150	*5,750	2,950	*4,300	2,000	*1,950	1,500	7.3
-1.5	kg	*4,700	*4,700	*8,850	5,050	*5,850	2,850	*4,250	1,950	*2,450	1,650	6.8
-3	kg	*7,900	*7,900	*7,650	5,100	*5,250	2,850			*3,300	2,000	5.9
-4.5	kg			*5,050	*5,050					*3,100	*3,100	4.4

Blade Up

B/A (m)		1.5m		3.0m		4.5m		6m		MAX REACH		
		Cf	Cs	Cf	Cs	Cf	Cs	Cf	Cs	Cf	Cs	Distance
6	kg					*3,200	*3,200			*1,700	*1,700	5.9
4.5	kg					*3,450	*3,450	*3,350	2,300	*1,650	*1,650	6.8
3	kg			*5,400	*5,400	*4,150	3,450	*3,600	2,200	*1,600	*1,600	7.3
1.5	kg			*7,850	5,600	*5,100	3,150	3,550	2,100	*2,000	1,550	7.4
ground	kg			*7,800	5,150	5,200	2,950	3,400	2,000	*1,950	1,500	7.3
-1.5	kg	*4,700	*4,700	*8,850	5,050	5,100	2,850	3,350	1,950	*2,450	1,650	6.8
-3	kg	*7,900	*7,900	*7,650	5,100	5,100	2,850			*3,300	2,000	5.9
-4.5	kg			*5,050	*5,050					*3,100	*3,100	4.4

Lifting capacity at the arm end without bucket.
For lifting capacity including bucket, weight of the bucket or the bucket with quick coupler must be deducted from the lifting capacities.
Lifting capacities are based on the machine standing on a firm, uniform supporting surface.



Rating over-front (Cf)



Rating over-side (Cs)

1. Do not attempt to lift or hold any load that is greater than these rated values at their specified load radius and height. Weight of all accessories must be deducted from the above lifting capacities.
2. The rated loads are in compliance with ISO 10567 Hydraulic Excavator Lift Capacity Rating Standard. They do not exceed 87% of hydraulic lifting capacity or 75% tipping load.
3. Ratings at bucket lift hook.

4. Lifting capacities are based on machine standing on level, firm and uniform ground.
5. *Indicates the load is limited by hydraulic capacity rather than tipping capacity.
6. Operator should be fully acquainted with the Operator's and Maintenance Instructions before operating this machine and rules for the safe operation of equipment should be adhered to at all times.

LIFTING CAPACITY (METRIC)

913FCR with 700 mm Shoes, 4,600 mm Boom, 2,900 mm Arm

A: load radius
B: load point height
C: Lifting capacity rating
Cf: Rated loads over front
Cs: Rated loads over side

Conditions

Boom length: 4,600 mm
Arm length: 2,900 mm
Bucket: None
counterweight: 3,000 kg
Shoes: 700 mm triple grouser shoes
Blade: YES

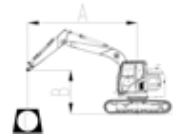

Blade Down

B/A (m)		1.5m		3.0m		4.5m		6m		MAX REACH		
		Cf	Cs	Cf	Cs	Cf	Cs	Cf	Cs	Cf	Cs	Distance
6	kg					*3,200	*3,200			*1,700	*1,700	5.9
4.5	kg					*3,450	*3,450	*3,350	2,350	*1,650	*1,650	6.8
3	kg			*5,400	*5,400	*4,150	3,500	*3,600	2,250	*1,600	*1,600	7.3
1.5	kg			*7,850	5,700	*5,100	3,200	*4,000	2,150	*2,000	1,550	7.4
ground	kg			*7,800	5,250	*5,750	3,000	*4,300	2,050	*1,950	1,550	7.3
-1.5	kg	*4,700	*4,700	*8,850	5,150	*5,850	2,900	*4,250	2,000	*2,450	1,700	6.8
-3	kg	*7,900	*7,900	*7,650	5,200	*5,250	2,900			*3,300	2,050	5.9
-4.5	kg			*5,050	*5,050					*3,100	*3,100	4.4

Blade Up

B/A (m)		1.5m		3.0m		4.5m		6m		MAX REACH		
		Cf	Cs	Cf	Cs	Cf	Cs	Cf	Cs	Cf	Cs	Distance
6	kg					*3,200	*3,200			*1,700	*1,700	5.9
4.5	kg					*3,450	*3,450	*3,350	2,350	*1,650	*1,650	6.8
3	kg			*5,400	*5,400	*4,150	3,500	*3,600	2,250	*1,600	*1,600	7.3
1.5	kg			*7,850	5,700	*5,100	3,200	3,600	2,150	*2,000	1,550	7.4
ground	kg			*7,800	5,250	5,300	3,000	3,500	2,050	*1,950	1,550	7.3
-1.5	kg	*4,700	*4,700	*8,850	5,150	5,200	2,900	3,400	2,000	*2,450	1,700	6.8
-3	kg	*7,900	*7,900	*7,650	5,200	5,200	2,900			*3,300	2,050	5.9
-4.5	kg			*5,050	*5,050					*3,100	*3,100	4.4

SPECIFICATIONS 913FCR

Lifting capacity at the arm end without bucket.
For lifting capacity including bucket, weight of the bucket or the bucket with quick coupler must be deducted from the lifting capacities.

Lifting capacities are based on the machine standing on a firm, uniform supporting surface.



Rating over-front (Cf)



Rating over-side (Cs)

1. Do not attempt to lift or hold any load that is greater than these rated values at their specified load radius and height. Weight of all accessories must be deducted from the above lifting capacities.
2. The rated loads are in compliance with ISO 10567 Hydraulic Excavator Lift Capacity Rating Standard. They do not exceed 87% of hydraulic lifting capacity or 75% tipping load.
3. Ratings at bucket lift hook.

4. Lifting capacities are based on machine standing on level, firm and uniform ground.
5. *Indicates the load is limited by hydraulic capacity rather than tipping capacity.
6. Operator should be fully acquainted with the Operator's and Maintenance Instructions before operating this machine and rules for the safe operation of equipment should be adhered to at all times.

LIFTING CAPACITY (METRIC)

913FCR with 500 mm Rubber Shoes, 4,600 mm Boom, 2,900 mm Arm

Conditions

A: load radius
B: load point height
C: Lifting capacity rating
Cf: Rated loads over front
Cs: Rated loads over side

Boom length: 4,600 mm
Arm length: 2,900 mm
Bucket: None
counterweight: 3,000 kg
Shoes: 500 mm rubber track shoes
Blade: YES

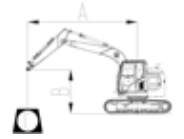

Blade Down

B/A (m)		1.5m		3.0m		4.5m		6m		MAX REACH		
		Cf	Cs	Cf	Cs	Cf	Cs	Cf	Cs	Cf	Cs	Distance
6	kg					*3,200	*3,200			*1,700	*1,700	5.9
4.5	kg					*3,450	*3,450	*3,350	2,250	*1,650	*1,650	6.8
3	kg			*5,400	*5,400	*4,150	3,350	*3,600	2,150	*1,600	1,550	7.3
1.5	kg			*7,850	5,500	*5,100	3,100	*4,000	2,050	*2,000	1,500	7.4
ground	kg			*7,800	5,050	*5,750	2,850	*4,300	1,950	*1,950	1,500	7.3
-1.5	kg	*4,700	*4,700	*8,850	4,900	*5,850	2,750	*4,250	1,900	*2,450	1,600	6.8
-3	kg	*7,900	*7,900	*7,650	5,000	*5,250	2,750			*3,300	1,950	5.9
-4.5	kg			*5,050	*5,050					*3,100	3,050	4.4

Blade Up

B/A (m)		1.5m		3.0m		4.5m		6m		MAX REACH		
		Cf	Cs	Cf	Cs	Cf	Cs	Cf	Cs	Cf	Cs	Distance
6	kg					*3,200	*3,200			*1,700	*1,700	5.9
4.5	kg					*3,450	*3,450	*3,350	2,250	*1,650	*1,650	6.8
3	kg			*5,400	*5,400	*4,150	3,350	3,600	2,150	*1,600	1,550	7.3
1.5	kg			*7,850	5,500	*5,100	3,100	3,450	2,050	*2,000	1,500	7.4
ground	kg			*7,800	5,050	5,100	2,850	3,350	1,950	*1,950	1,500	7.3
-1.5	kg	*4,700	*4,700	*8,850	4,900	5,000	2,750	3,300	1,900	*2,450	1,600	6.8
-3	kg	*7,900	*7,900	*7,650	5,000	5,000	2,750			*3,300	1,950	5.9
-4.5	kg			*5,050	*5,050					*3,100	3,050	4.4

SPECIFICATIONS 915F_{CR}

Operating weight 15,400-16,300 kg
(33,951-35,935 lbs)

Operating weight includes coolant, lubricants, full fuel tank, cab, standard shoes, monoboam, arm, bucket and operator 75 kg (165 lbs).

Bucket capacity 0.55 m³ (0.72 yd³)

ENGINE

Description

Cummins EU Stage V, turbocharged, 4 cylinder, 4 stroke, water cooled.

Emission rating Stage V

Engine manufacturer Cummins

Engine model F3.8

Aspiration Turbocharged

Charged air cooling Aftercooler

Cooling fan drive Direct

Displacement 3.8 L (1 gal)

Rated speed 2,200 rpm

Engine Output - Gross (SAE J1349 / ISO 9249) 90 kW (120.7 hp)

Engine Output - Net (SAE J1995 / ISO 14396) 84.5 kW (113.3 hp)

Maximum torque 500 N·m (369 lbf·ft) @1,500 rpm

Bore x Stroke 102 x 115 mm (4" x 4.5")

UNDERCARRIAGE

Track shoe each side 44 (1.7")

Link pitch 175 mm (6.9" metal)

Shoe width, triple grouser 500 mm (20")

Bottom rollers each side 7

Top rollers each side 2

SWING SYSTEM

Description

Planetary gear reduction driven by high torque axial piston motor, with oil disk brake. Swing parking brake resets within five seconds after swing pilot controls return to neutral.

Swing speed 11.3 rpm

Swing torque 36,790 N·m (27,135 lbf·ft)

HYDRAULIC SYSTEM

Main pump

Type Two variable displacement

Maximum flow 2 x 117 L/min (2 x 30.9 gal/min)

Relief valve setting

Implement 34.3 / 37 MPa (4,975 / 5,410 psi)

Travel circuit 34.3 MPa (4,975 psi)

Slew circuit 26.5 MPa (3,843 psi)

Pilot circuitw 3.9 MPa (566 psi)

Hydraulic cylinders

Boom Cylinder – Bore x Stroke $\Phi 105 \times 1,000$ mm (4.1" x 3'3")

Arm Cylinder – Bore x Stroke $\Phi 115 \times 1,175$ mm (4.5" x 3'10")

Bucket Cylinder – Bore x Stroke $\Phi 95 \times 885$ mm (3.7" x 2'11")

ELECTRIC SYSTEM

System voltage 12 V

Batteries 24 V

Alternator 24 V - 70 A

Starter 24 V - 4.8 kW (24 V - 6.4 hp)

SERVICE CAPACITIES

Fuel tank 200 L (52.8 gal)

Engine oil 12 L (3.2 gal)

Final drive (each) 2.5 L (0.7 gal)

Swing drive 3 L (0.8 gal)

Cooling system 20 L (5.3 gal)

Hydraulic reservoir 100 L (26.4 gal)

Hydraulic system total 160 L (42.3 gal)

DEF tank 25 L (6.6 gal)

SOUND PERFORMANCE

Interior Sound Power Level (ISO 6396) 72 dB(A)

Exterior Sound Power Level (ISO 6395) 99 dB(A)

DRIVE AND BRAKES

Description

Steering controlled by two hand levers with pedals.

Max. travel speed High: 4.9 km/h (3 mph)
Low: 2.9 km/h (1.8 mph)

Gradeability 35°/70%

Max. drawbar pull 122 kN (27,427 lbf)

SPECIFICATIONS 915F_{CR}

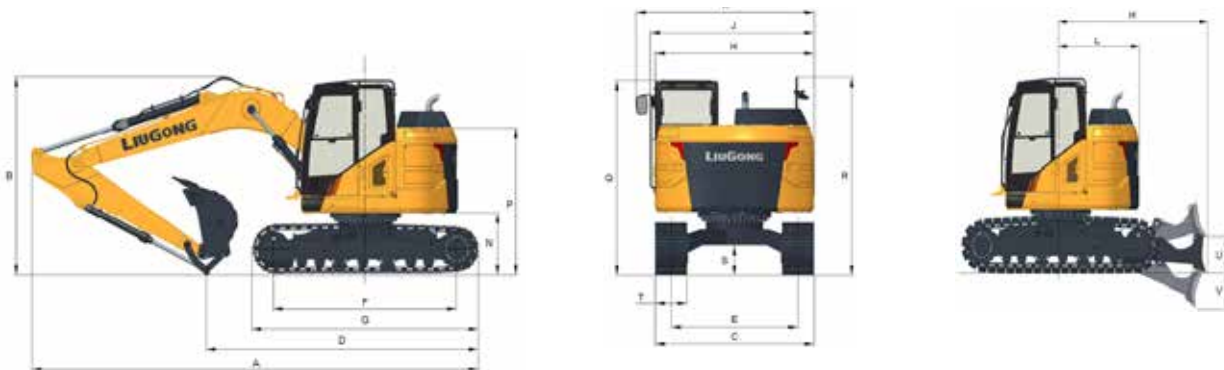

DIMENSIONS	MONO BOOM	MONO BOOM	TWO-PIECE BOOM
Boom		4,600 mm	5,050 mm
Arm Options	2,500 mm	2,900 mm	2,500 mm
A Shipping Length	7,335 mm	7,290 mm	7,590 mm
B Shipping Height – Top of Boom	2,980 mm	3,255 mm	3,115 mm
C Undercarriage Width - 500 mm (20") shoes	2,490 mm	2,490 mm	2,490 mm
- 600 mm (24") shoes	2,590 mm	2,590 mm	2,590 mm
- 700 mm (28") shoes	2,690 mm	2,690 mm	2,690 mm
D Shipping length on ground	4,470 mm	4,410 mm	4,965 mm
E Track Gauge	1,990 mm	1,990 mm	1,990 mm
F Length to Center of Rollers	3,010 mm	3,010 mm	3,010 mm
G Track Length	3,745 mm	3,745 mm	3,745 mm
H Overall Width of Upper Structure	2,490 mm	2,490 mm	2,490 mm
J Overall Width of Upper Structure including cab handrail	2,570 mm	2,570 mm	2,570 mm
K Overall Width of Upper Structure including cab rearview mirror	2,790 mm	2,790 mm	2,790 mm
L Tail Swing Radius	1,525 mm	1,525 mm	1,525 mm
M Distance of swing center to blade	2,800 mm	2,800 mm	2,800 mm
N Counterweight Ground Clearance	935 mm	935 mm	935 mm
P Overall Height of Counterweight	2,215 mm	2,215 mm	2,215 mm
Q Overall Height of Cab	2,885 mm	2,885 mm	2,885 mm
Overall Height of Cab including Halo	3,025 mm	3,025 mm	3,025 mm
Overall Height of Cab including FOP's Guard	3,015 mm	3,015 mm	3,015 mm
R Overall Height of Platform handrail	2,935 mm	2,935 mm	2,935 mm
S Min. Ground Clearance	450 mm	450 mm	450 mm
T Track Shoe Width	500 mm	500 mm	500 mm
U Blade, max. lifting height	540 mm	540 mm	540 mm
V Blade, max. digging depth	540 mm	540 mm	540 mm
Blade width (with 500 mm shoes)	2,490 mm	2,490 mm	2,490 mm
Blade width (with 600 mm shoes)	2,590 mm	2,590 mm	2,590 mm
Blade width (with 700 mm shoes)	2,690 mm	2,690 mm	2,690 mm

MACHINE WEIGHTS & GROUND PRESSURE

Shoe width	MONO BOOM		TWO-PIECE BOOM	
	Operating weight	Ground pressure	Operating weight	Ground pressure
500 mm	15,400 kg	45.8 kPa	15,900 kg	47.3 kPa
600 mm	15,600 kg	38.7 kPa	16,100 kg	39.9 kPa
700 mm	15,800 kg	33.6 kPa	16,300 kg	34.6 kPa
500 mm rubber crawler pads	15,400 kg	45.6 kPa	15,900 kg	47.0 kPa

Operating weight, including 2,500 mm arm, 480 kg bucket, operator, lubricant, coolant, full fuel tank and the standard equipment. Additional weight with blade: +1,000 kg



BOOM DIMENSIONS

Boom	Monoboom	2 Piece Boom
A Length	4,800 mm	5,050 mm
B Height	1,500 mm	1,600 mm
C Width	750 mm	750 mm
Weight	1,170 kg	1,460 kg

Cylinder, piping and pin included. Boom cylinder pin excluded.

ARM DIMENSIONS

Arm	2,500 mm	2,900 mm
A Length	3,300 mm	3,700 mm
B Height	650 mm	700 mm
C Width	450 mm	450 mm
Weight	640 kg	670 kg

Cylinder, linkage and pin included.

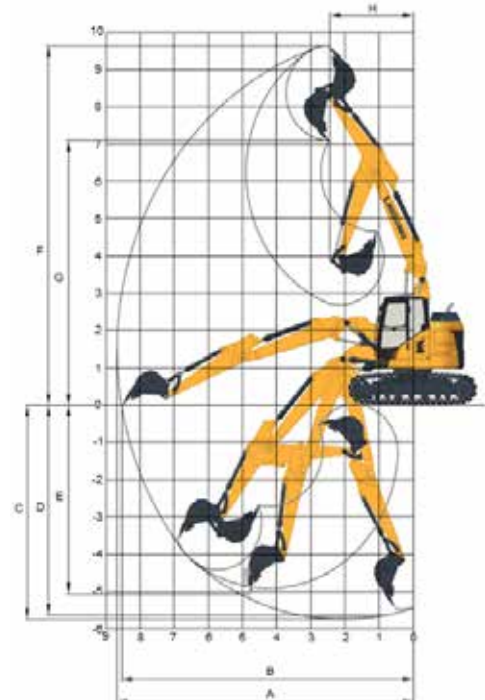
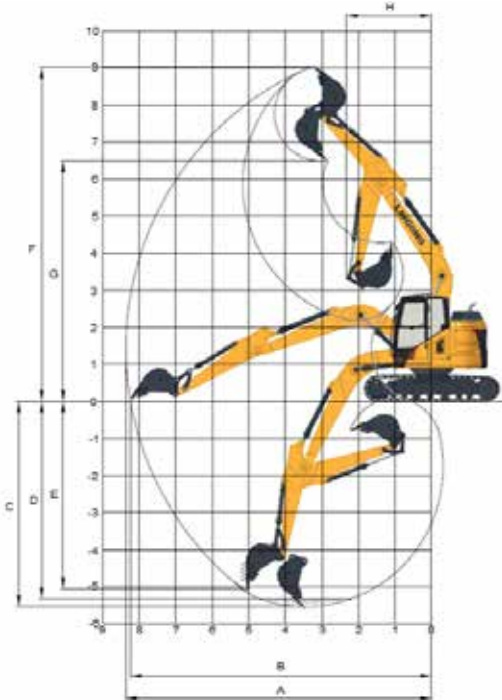

WORKING RANGE

		MONO BOOM	TWO-PIECE BOOM
Boom Length		4,800 mm	5,050 mm
Arm Options		2,500 mm	2,900 mm
A. Max. Digging Reach		8,365 mm	8,670 mm
B. Max. Digging Reach on Ground		8,235 mm	8,535 mm
C. Max. Digging Depth		5,515 mm	5,745 mm
D. Max. Digging Depth, 2.5m (8') level		5,300 mm	5,630 mm
E. Max. Vertical Wall Digging Depth		5,030 mm	5,060 mm
F. Max. Cutting Height		9,040 mm	9,640 mm
G. Max. Dumping Height		6,510 mm	7,090 mm
H. Min. Front Swing Radius		2,325 mm	2,435 mm
Bucket Digging Force (ISO)	Normal	89.8 kN	89.8 kN
	Power Boost	96.9 kN	96.9 kN
Arm Digging Force (ISO)	Normal	64.9 kN	58 kN
	Power Boost	70 kN	63.5 kN
Bucket Capacity (Standard)		0.55 m ³	0.55 m ³
Bucket Tip Radius		1,085 mm	1,085 mm

SPECIFICATIONS 915FCR

Lifting capacity at the arm end without bucket.

For lifting capacity including bucket, weight of the bucket or the bucket with quick coupler must be deducted from the lifting capacities.

Lifting capacities are based on the machine standing on a firm, uniform supporting surface.



Rating over-front (Cf)



Rating over-side (Cs)

- Do not attempt to lift or hold any load that is greater than these rated values at their specified load radius and height. Weight of all accessories must be deducted from the above lifting capacities.
- The rated loads are in compliance with ISO 10567 Hydraulic Excavator Lift Capacity Rating Standard. They do not exceed 87% of hydraulic lifting capacity or 75% tipping load.
- Ratings at bucket lift hook.
- Lifting capacities are based on machine standing on level, firm and uniform ground.
- *Indicates the load is limited by hydraulic capacity rather than tipping capacity.
- Operator should be fully acquainted with the Operator's and Maintenance Instructions before operating this machine and rules for the safe operation of equipment should be adhered to at all times.

LIFTING CAPACITY (METRIC)

915FCR with 500 mm Shoes, MONO Boom, 2,500 mm Arm

Conditions

Boom length: 4,800 mm
 Arm length: 2,500 mm
 Shoes: 500 mm triple grouser shoes
 Bucket: None
 Counterweight: 3,500 kg
 Blade: None

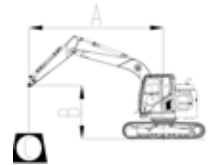

A: Load radius
 B: Load point height
 C: Lifting capacity rating
 Cf: Rating loads over front
 Cs: Rating loads over side or 360°

B/A (m)	1.5		3.0		4.5		6		MAX REACH		A (m)	
	Cf	Cs	Cf	Cs	Cf	Cs	Cf	Cs	Cf	Cs		
6	kg				*3,600	*3,600			*2,050	*2,050	5.4	
4.5	kg				*3,800	*3,800	*3,350	2,500	*2,350	2,300	6.3	
3	kg		*6,150	*6,150	*4,500	3,750	*3,800	2,450	*2,000	1,950	6.9	
1.5	kg		*8,450	6,100	*5,350	3,500	3,900	2,350	*2,550	1,850	7.0	
0	kg		*7,200	5,750	5,800	3,300	3,800	2,250	*2,400	1,850	6.9	
-1.5	kg	*5,150	*5,150	*8,600	5,700	5,700	3,200	3,800	2,200	*2,800	2,050	6.4
-3	kg	**9,150	**9,150	*7,150	5,800	**4,900	*3,250		*3,750	2,600	5.4	

LIFTING CAPACITY (METRIC)

915FCR with 600 mm Shoes, MONO Boom, 2,500 mm Arm

Conditions

Boom length: 4,800 mm
 Arm length: 2,500 mm
 Shoes: 600 mm triple grouser shoes
 Bucket: None
 Counterweight: 3,500 kg
 Blade: None

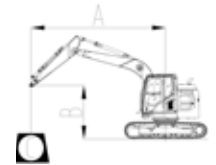

A: Load radius
 B: Load point height
 C: Lifting capacity rating
 Cf: Rating loads over front
 Cs: Rating loads over side or 360°

B/A (m)	1.5		3.0		4.5		6		MAX REACH		A (m)	
	Cf	Cs	Cf	Cs	Cf	Cs	Cf	Cs	Cf	Cs		
6	kg				*3,600	*3,600			*2,050	*2,050	5.4	
4.5	kg				*3,800	*3,800	*3,350	2,550	*2,350	2,350	6.3	
3	kg		*6,150	*6,150	*4,500	3,800	*3,800	2,500	*2,000	*2,000	6.9	
1.5	kg		*8,450	6,200	*5,350	3,550	4,000	2,400	*2,550	1,900	7.0	
0	kg		*7,200	5,850	*5,850	3,350	3,900	2,300	*2,400	1,900	6.9	
-1.5	kg	*5,150	*5,150	*8,600	5,800	*5,800	3,250	3,850	*2,250	*2,800	2,100	6.4
-3	kg	*9,150	*9,150	*7,150	*5,900	*4,900	*3,300		*3,750	*2,650	5.4	

Lifting capacity at the arm end without bucket.
For lifting capacity including bucket, weight of the bucket or the bucket with quick coupler must be deducted from the lifting capacities.
Lifting capacities are based on the machine standing on a firm, uniform supporting surface.



Rating over-front (Cf)



Rating over-side (Cs)

- Do not attempt to lift or hold any load that is greater than these rated values at their specified load radius and height. Weight of all accessories must be deducted from the above lifting capacities.
- The rated loads are in compliance with ISO 10567 Hydraulic Excavator Lift Capacity Rating Standard. They do not exceed 87% of hydraulic lifting capacity or 75% tipping load.
- Ratings at bucket lift hook.
- Lifting capacities are based on machine standing on level, firm and uniform ground.
- *Indicates the load is limited by hydraulic capacity rather than tipping capacity.
- Operator should be fully acquainted with the Operator's and Maintenance Instructions before operating this machine and rules for the safe operation of equipment should be adhered to at all times.

LIFTING CAPACITY (METRIC)

915FCR with 700 mm Shoes, MONO Boom, 2,500 mm Arm

Conditions

- A: Load radius
- B: Load point height
- C: Lifting capacity rating
- Cf: Rating loads over front
- Cs: Rating loads over side or 360°

- Boom length: 4,800 mm
- Arm length: 2,500 mm
- Shoes: 700 mm triple grouser shoes
- Bucket: None
- Counterweight: 3,500 kg
- Blade: None

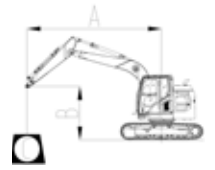

B/A (m)		1.5		3.0		4.5		6		MAX REACH		A (m)
		Cf	Cs	Cf	Cs	Cf	Cs	Cf	Cs	Cf	Cs	
6	kg					*3,600	*3,600			*2,050	*2,050	5.4
4.5	kg					*3,800	*3,800	*3,350	2,600	*2,350	*2,350	6.3
3	kg			*6,150	*6,150	*4,500	3,850	*3,800	2,550	*2,000	*2,000	6.9
1.5	kg			*8,450	6,300	*5,350	3,600	4,050	2,450	*2,550	1,950	7.0
0	kg			*7,200	5,950	*5,850	3,400	3,950	2,350	*2,400	1,950	6.9
-1.5	kg	*5,150	*5,150	*8,600	5,900	*5,800	3,350	3,900	*2,300	*2,800	2,150	6.4
-3	kg	*9,150	*9,150	*7,150	*6,000	*4,900	*3,350			*3,750	*2,700	5.4

LIFTING CAPACITY (METRIC)

915FCR with 500 mm Shoes, MONO Boom, 2,500 mm Arm

Conditions

- A: Load radius
- B: Load point height
- C: Lifting capacity rating
- Cf: Rating loads over front
- Cs: Rating loads over side or 360°

- Boom length: 4,800 mm
- Arm length: 2,500 mm
- Shoes: 500 mm rubber track shoes
- Bucket: None
- Counterweight: 3,500 kg
- Blade: None

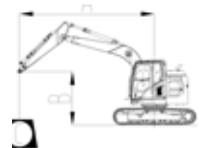

B/A (m)		1.5		3.0		4.5		6		MAX REACH		A (m)
		Cf	Cs	Cf	Cs	Cf	Cs	Cf	Cs	Cf	Cs	
6	kg					*3,600	*3,600			*2,050	*2,050	5.4
4.5	kg					*3,800	*3,800	*3,350	2,500	*2,350	2,300	6.3
3	kg			*6,150	*6,150	*4,500	3,700	*3,800	2,450	*2,000	1,950	6.9
1.5	kg			*8,450	6,050	*5,350	3,450	3,900	2,350	*2,550	1,850	7.0
0	kg			*7,200	5,750	5,800	3,250	3,800	2,250	*2,400	1,850	6.9
-1.5	kg	*5,150	*5,150	*8,600	5,700	5,700	3,200	3,750	*2,200	*2,800	2,050	6.4
-3	kg	*9,150	*9,150	*7,150	*5,800	*4,900	*3,250			*3,750	*2,550	5.4

SPECIFICATIONS 915FCR

Lifting capacity at the arm end without bucket.
For lifting capacity including bucket, weight of the bucket or the bucket with quick coupler must be deducted from the lifting capacities.

Lifting capacities are based on the machine standing on a firm, uniform supporting surface.



Rating over-front (Cf)



Rating over-side (Cs)

1. Do not attempt to lift or hold any load that is greater than these rated values at their specified load radius and height. Weight of all accessories must be deducted from the above lifting capacities.
2. The rated loads are in compliance with ISO 10567 Hydraulic Excavator Lift Capacity Rating Standard. They do not exceed 87% of hydraulic lifting capacity or 75% tipping load.
3. Ratings at bucket lift hook.

4. Lifting capacities are based on machine standing on level, firm and uniform ground.
5. *Indicates the load is limited by hydraulic capacity rather than tipping capacity.
6. Operator should be fully acquainted with the Operator's and Maintenance Instructions before operating this machine and rules for the safe operation of equipment should be adhered to at all times.

LIFTING CAPACITY (METRIC)

915FCR with 500 mm Shoes, MONO Boom, 2,900 mm Arm

Conditions

Boom length: 4,800 mm
Arm length: 2,900 mm
Shoes: 500 mm triple grouser shoes
Bucket: None
Counterweight: 3,500 kg
Blade: None

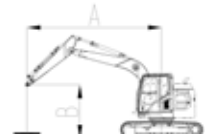

A: Load radius
B: Load point height
C: Lifting capacity rating
Cf: Rating loads over front
Cs: Rating loads over side or 360°

B/A (m)	1.5		3.0		4.5		6		MAX REACH		A (m)	
	Cf	Cs	Cf	Cs	Cf	Cs	Cf	Cs	Cf	Cs		
6	kg				*3,200	*3,200			*1,700	*1,700	5.9	
4.5	kg				*3,450	*3,450	*3,350	2,550	*1,650	*1,650	6.8	
3	kg			*5,400	*5,400	*4,150	3,800	*3,600	2,450	*1,600	*1,600	7.3
1.5	kg			*7,900	6,250	*5,100	3,500	3,950	2,350	*2,000	1,750	7.4
0	kg			*7,800	5,800	*5,750	3,300	3,800	2,250	*1,950	1,700	7.3
-1.5	kg	*4,700	*4,700	*8,850	5,650	5,700	3,200	3,750	*2,200	*2,400	1,900	6.8
-3		*7,900	*7,900	*7,650	5,750	*5,250	3,200			*3,250	2,250	5.9
-4.5	kg			*5,050	*5,050					*3,100	*3,100	4.4

LIFTING CAPACITY (METRIC)

915FCR with 600 mm Shoes, MONO Boom, 2,900 mm Arm

Conditions

Boom length: 4,800 mm
Arm length: 2,900 mm
Shoes: 600 mm triple grouser shoes
Bucket: None
Counterweight: 3,500 kg
Blade: None

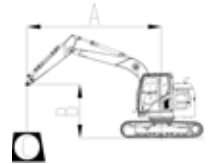

A: Load radius
B: Load point height
C: Lifting capacity rating
Cf: Rating loads over front
Cs: Rating loads over side or 360°

B/A (m)	1.5		3.0		4.5		6		MAX REACH		A (m)	
	Cf	Cs	Cf	Cs	Cf	Cs	Cf	Cs	Cf	Cs		
6	kg				*3,200	*3,200			*1,700	*1,700	5.9	
4.5	kg				*3,450	*3,450	*3,350	2,600	*1,650	*1,650	6.8	
3	kg			*5,400	*5,400	*4,150	3,850	*3,600	2,500	*1,600	*1,600	7.3
1.5	kg			*7,900	6,350	*5,100	3,600	4,000	2,400	*2,000	1,750	7.4
0	kg			*7,800	5,900	*5,750	3,350	3,900	2,300	*1,950	1,750	7.3
-1.5	kg	*4,700	*4,700	*8,850	5,800	5,800	3,250	3,800	*2,250	*2,400	1,900	6.8
-3		*7,900	*7,900	*7,650	5,850	*5,250	3,250			*3,250	2,300	5.9
-4.5	kg			*5,050	*5,050					*3,100	*3,100	4.4

Lifting capacity at the arm end without bucket.
For lifting capacity including bucket, weight of the bucket or the bucket with quick coupler must be deducted from the lifting capacities.

Lifting capacities are based on the machine standing on a firm, uniform supporting surface.



Rating over-front (Cf)



Rating over-side (Cs)

1. Do not attempt to lift or hold any load that is greater than these rated values at their specified load radius and height. Weight of all accessories must be deducted from the above lifting capacities.
2. The rated loads are in compliance with ISO 10567 Hydraulic Excavator Lift Capacity Rating Standard. They do not exceed 87% of hydraulic lifting capacity or 75% tipping load.
3. Ratings at bucket lift hook.

4. Lifting capacities are based on machine standing on level, firm and uniform ground.
5. *Indicates the load is limited by hydraulic capacity rather than tipping capacity.
6. Operator should be fully acquainted with the Operator's and Maintenance Instructions before operating this machine and rules for the safe operation of equipment should be adhered to at all times.

LIFTING CAPACITY (METRIC)

915FCR with 700 mm Shoes, MONO Boom, 2,900 mm Arm

Conditions

Boom length: 4,800 mm
Arm length: 2,900 mm
Shoes: 700 mm triple grouser shoes
Bucket: None
Counterweight: 3,500 kg
Blade: None

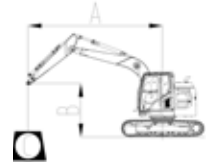

A: Load radius
B: Load point height
C: Lifting capacity rating
Cf: Rating loads over front
Cs: Rating loads over side or 360°

B/A (m)		1.5		3.0		4.5		6		MAX REACH		A (m)
		Cf	Cs	Cf	Cs	Cf	Cs	Cf	Cs	Cf	Cs	
6	kg					*3,200	*3,200			*1,700	*1,700	5.9
4.5	kg					*3,450	*3,450	*3,350	2,650	*1,650	*1,650	6.8
3	kg			*5,400	*5,400	*4,150	3,900	*3,600	2,550	*1,600	*1,600	7.3
1.5	kg			*7,900	6,450	*5,100	3,650	*4,000	2,450	*2,000	1,800	7.4
0	kg			*7,800	6,000	*5,750	3,400	3,950	2,350	*1,950	1,800	7.3
-1.5	kg	*4,700	*4,700	*8,850	5,900	*5,850	3,300	3,900	*2,300	*2,400	1,950	6.8
-3		*7,900	*7,900	*7,650	5,950	*5,250	3,300			*3,250	2,350	5.9
-4.5	kg			*5,050	*5,050					*3,100	*3,100	4.4

LIFTING CAPACITY (METRIC)

915FCR with 500 mm Shoes, MONO Boom, 2,900 mm Arm

Conditions

Boom length: 4,800 mm
Arm length: 2,900 mm
Shoes: 500 mm rubber track shoes
Bucket: None
Counterweight: 3,500 kg
Blade: None

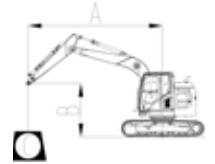

A: Load radius
B: Load point height
C: Lifting capacity rating
Cf: Rating loads over front
Cs: Rating loads over side or 360°

B/A (m)		1.5		3.0		4.5		6		MAX REACH		A (m)
		Cf	Cs	Cf	Cs	Cf	Cs	Cf	Cs	Cf	Cs	
6	kg					*3,200	*3,200			*1,700	*1,700	5.9
4.5	kg					*3,450	*3,450	*3,350	2,550	*1,650	*1,650	6.8
3	kg			*5,400	*5,400	*4,150	3,800	*3,600	2,450	*1,600	*1,600	7.3
1.5	kg			*7,900	6,250	*5,100	3,500	3,900	2,350	*2,000	1,700	7.4
0	kg			*7,800	5,750	*5,750	3,300	3,800	2,250	*1,950	1,700	7.3
-1.5	kg	*4,700	*4,700	*8,850	5,650	5,700	3,200	3,750	*2,200	*2,400	1,850	6.8
-3		*7,900	*7,900	*7,650	5,700	*5,250	3,200			*3,250	2,250	5.9
-4.5	kg			*5,050	*5,050					*3,100	*3,100	4.4

SPECIFICATIONS 915FCR

Lifting capacity at the arm end without bucket.
For lifting capacity including bucket, weight of the bucket or the bucket with quick coupler must be deducted from the lifting capacities.
Lifting capacities are based on the machine standing on a firm, uniform supporting surface.



Rating over-front (Cf)



Rating over-side (Cs)

1. Do not attempt to lift or hold any load that is greater than these rated values at their specified load radius and height. Weight of all accessories must be deducted from the above lifting capacities.
2. The rated loads are in compliance with ISO 10567 Hydraulic Excavator Lift Capacity Rating Standard. They do not exceed 87% of hydraulic lifting capacity or 75% tipping load.
3. Ratings at bucket lift hook.
4. Lifting capacities are based on machine standing on level, firm and uniform ground.
5. *Indicates the load is limited by hydraulic capacity rather than tipping capacity.
6. Operator should be fully acquainted with the Operator's and Maintenance Instructions before operating this machine and rules for the safe operation of equipment should be adhered to at all times.

LIFTING CAPACITY (METRIC)

915FCR with 500 mm Shoes, MONO Boom, 2,500 mm Arm

A: Load radius
B: Load point height
C: Lifting capacity rating
Cf: Rating loads over front
Cs: Rating loads over side or 360°

Conditions

Boom length: 4,800 mm
Arm length: 2,500 mm
Shoes: 500 mm triple grouser shoes
Bucket: None
Counterweight: 3,500 kg
Blade: YES

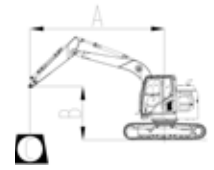

Blade Down

B/A (m)		1.5		3.0		4.5		6		MAX REACH		A (m)
		Cf	Cs	Cf	Cs	Cf	Cs	Cf	Cs	Cf	Cs	
6	kg					*3,600	*3,600			*2,050	*2,050	5.4
4.5	kg					*3,800	*3,800	*3,350	2,450	*2,350	2,250	6.3
3	kg			*6,150	*6,150	*4,500	3,650	*3,800	2,400	*2,000	1,900	6.9
1.5	kg			*8,450	6,000	*5,350	3,400	*4,150	2,300	*2,550	1,850	7.0
0	kg			*7,200	5,650	*5,850	3,200	*4,350	2,200	*2,400	1,850	6.9
-1.5	kg	*5,150	*5,150	*8,600	5,600	*5,800	3,150	*4,200	*2,150	*2,800	2,000	6.4
-3	kg	*9,150	*9,150	*7,150	*5,700	*4,900	3,200			*3,750	*2,550	5.4

Blade Up

B/A (m)		1.5		3.0		4.5		6		MAX REACH		A (m)
		Cf	Cs	Cf	Cs	Cf	Cs	Cf	Cs	Cf	Cs	
6	kg					*3,600	*3,600			*2,050	*2,050	5.4
4.5	kg					*3,800	*3,800	*3,350	2,450	*2,350	2,250	6.3
3	kg			*6,150	*6,150	*4,500	3,650	*3,800	2,400	*2,000	1,900	6.9
1.5	kg			*8,450	6,000	*5,350	3,400	3,950	2,300	*2,550	1,850	7.0
0	kg			*7,200	5,650	5,850	3,200	3,850	2,200	*2,400	1,850	6.9
-1.5	kg	*5,150	*5,150	*8,600	5,600	5,750	3,150	3,800	*2,150	*2,800	2,000	6.4
-3	kg	*9,150	*9,150	*7,150	*5,700	*4,900	3,200			*3,750	*2,550	5.4

Lifting capacity at the arm end without bucket.
For lifting capacity including bucket, weight of the bucket or the bucket with quick coupler must be deducted from the lifting capacities.
Lifting capacities are based on the machine standing on a firm, uniform supporting surface.



Rating over-front (Cf)



Rating over-side (Cs)

1. Do not attempt to lift or hold any load that is greater than these rated values at their specified load radius and height. Weight of all accessories must be deducted from the above lifting capacities.
2. The rated loads are in compliance with ISO 10567 Hydraulic Excavator Lift Capacity Rating Standard. They do not exceed 87% of hydraulic lifting capacity or 75% tipping load.
3. Ratings at bucket lift hook.

4. Lifting capacities are based on machine standing on level, firm and uniform ground.
5. *Indicates the load is limited by hydraulic capacity rather than tipping capacity.
6. Operator should be fully acquainted with the Operator's and Maintenance Instructions before operating this machine and rules for the safe operation of equipment should be adhered to at all times.

LIFTING CAPACITY (METRIC)

915FCR with 600 mm Shoes, MONO Boom, 2,500 mm Arm

Conditions

A: Load radius
B: Load point height
C: Lifting capacity rating
Cf: Rating loads over front
Cs: Rating loads over side or 360°

Boom length: 4,800 mm
Arm length: 2,500 mm
Shoes: 600 mm triple grouser shoes
Bucket: None
Counterweight: 3,500 kg
Blade: YES

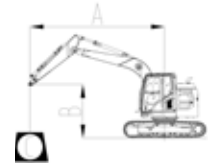

Blade Down

B/A (m)		1.5		3.0		4.5		6		MAX REACH		A (m)
		Cf	Cs	Cf	Cs	Cf	Cs	Cf	Cs	Cf	Cs	
6	kg					*3,600	*3,600			*2,050	*2,050	5.4
4.5	kg					*3,800	*3,800	*3,350	2,500	*2,350	2,300	6.3
3	kg			*6,150	*6,150	*4,500	3,750	*3,800	2,450	*2,000	1,950	6.9
1.5	kg			*8,450	6,100	*5,350	3,450	*4,150	2,350	*2,550	1,850	7.0
0	kg			*7,200	5,750	*5,850	3,300	*4,350	2,250	*2,400	1,850	6.9
-1.5	kg	*5,150	*5,150	*8,600	5,700	*5,800	3,200	*4,200	*2,200	*2,800	2,050	6.4
-3	kg	*9,150	*9,150	*7,150	*5,800	*4,900	3,250			*3,750	*2,600	5.4

Blade Up

B/A (m)		1.5		3.0		4.5		6		MAX REACH		A (m)
		Cf	Cs	Cf	Cs	Cf	Cs	Cf	Cs	Cf	Cs	
6	kg					*3,600	*3,600			*2,050	*2,050	5.4
4.5	kg					*3,800	*3,800	*3,350	2,500	*2,350	2,300	6.3
3	kg			*6,150	*6,150	*4,500	3,750	*3,800	2,450	*2,000	1,950	6.9
1.5	kg			*8,450	6,100	*5,350	3,450	4,000	2,350	*2,550	1,850	7.0
0	kg			*7,200	5,750	*5,850	3,300	3,900	2,250	*2,400	1,850	6.9
-1.5	kg	*5,150	*5,150	*8,600	5,700	*5,800	3,200	3,850	*2,200	*2,800	2,050	6.4
-3	kg	*9,150	*9,150	*7,150	*5,800	*4,900	3,250			*3,750	*2,600	5.4

SPECIFICATIONS 915FCR

Lifting capacity at the arm end without bucket.
For lifting capacity including bucket, weight of the bucket or the bucket with quick coupler must be deducted from the lifting capacities.
Lifting capacities are based on the machine standing on a firm, uniform supporting surface.



Rating over-front (Cf)



Rating over-side (Cs)

- Do not attempt to lift or hold any load that is greater than these rated values at their specified load radius and height. Weight of all accessories must be deducted from the above lifting capacities.
- The rated loads are in compliance with ISO 10567 Hydraulic Excavator Lift Capacity Rating Standard. They do not exceed 87% of hydraulic lifting capacity or 75% tipping load.
- Ratings at bucket lift hook.
- Lifting capacities are based on machine standing on level, firm and uniform ground.
- *Indicates the load is limited by hydraulic capacity rather than tipping capacity.
- Operator should be fully acquainted with the Operator's and Maintenance Instructions before operating this machine and rules for the safe operation of equipment should be adhered to at all times.

LIFTING CAPACITY (METRIC)

915FCR with 700 mm Shoes, MONO Boom, 2,500 mm Arm

Conditions

A: Load radius
B: Load point height
C: Lifting capacity rating
Cf: Rating loads over front
Cs: Rating loads over side or 360°

Boom length: 4,800 mm
Arm length: 2,500 mm
Shoes: 700 mm triple grouser shoes
Bucket: None
Counterweight: 3,500 kg
Blade: YES

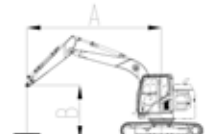

Blade Down

B/A (m)		1.5		3.0		4.5		6		MAX REACH		A (m)
		Cf	Cs	Cf	Cs	Cf	Cs	Cf	Cs	Cf	Cs	
6	kg					*3,600	*3,600			*2,050	*2,050	5.4
4.5	kg					*3,800	*3,800	*3,350	2,550	*2,350	2,350	6.3
3	kg			*6,150	*6,150	*4,500	3,800	*3,800	2,500	*2,000	*2,000	6.9
1.5	kg			*8,450	6,200	*5,350	3,500	*4,150	2,350	*2,550	1,900	7.0
0	kg			*7,200	5,850	*5,850	3,350	*4,350	2,300	*2,400	1,900	6.9
-1.5	kg	*5,150	*5,150	*8,600	5,800	*5,800	3,250	*4,200	*2,250	*2,800	2,100	6.4
-3	kg	*9,150	*9,150	*7,150	*5,900	*4,900	3,300			*3,750	*2,600	5.4

Blade Up

B/A (m)		1.5		3.0		4.5		6		MAX REACH		A (m)
		Cf	Cs	Cf	Cs	Cf	Cs	Cf	Cs	Cf	Cs	
6	kg					*3,600	*3,600			*2,050	*2,050	5.4
4.5	kg					*3,800	*3,800	*3,350	2,550	*2,350	2,350	6.3
3	kg			*6,150	*6,150	*4,500	3,800	*3,800	2,500	*2,000	*2,000	6.9
1.5	kg			*8,450	6,200	*5,350	3,500	4,050	2,350	*2,550	1,900	7.0
0	kg			*7,200	5,850	*5,850	3,350	3,950	2,300	*2,400	1,900	6.9
-1.5	kg	*5,150	*5,150	*8,600	5,800	*5,800	3,250	3,950	*2,250	*2,800	2,100	6.4
-3	kg	*9,150	*9,150	*7,150	*5,900	*4,900	3,300			*3,750	*2,600	5.4

Lifting capacity at the arm end without bucket.
For lifting capacity including bucket, weight of the bucket or the bucket with quick coupler must be deducted from the lifting capacities.
Lifting capacities are based on the machine standing on a firm, uniform supporting surface.



Rating over-front (Cf)



Rating over-side (Cs)

- Do not attempt to lift or hold any load that is greater than these rated values at their specified load radius and height. Weight of all accessories must be deducted from the above lifting capacities.
- The rated loads are in compliance with ISO 10567 Hydraulic Excavator Lift Capacity Rating Standard. They do not exceed 87% of hydraulic lifting capacity or 75% tipping load.
- Ratings at bucket lift hook.
- Lifting capacities are based on machine standing on level, firm and uniform ground.
- *Indicates the load is limited by hydraulic capacity rather than tipping capacity.
- Operator should be fully acquainted with the Operator's and Maintenance Instructions before operating this machine and rules for the safe operation of equipment should be adhered to at all times.

LIFTING CAPACITY (METRIC)

915FCR with 500 mm Shoes, MONO Boom, 2,500 mm Arm

Conditions

- A: Load radius
- B: Load point height
- C: Lifting capacity rating
- Cf: Rating loads over front
- Cs: Rating loads over side or 360°

Boom length: 4,800 mm
Arm length: 2,500 mm
Shoes: 500 mm rubber track shoes
Bucket: None
Counterweight: 3,500 kg
Blade: YES

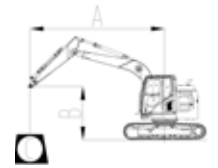

Blade Down

B/A (m)	1.5		3.0		4.5		6		MAX REACH			
	Cf	Cs	Cf	Cs	Cf	Cs	Cf	Cs	Cf	Cs	A (m)	
6	kg				*3,600	*3,600			*2,050	*2,050	5.4	
4.5	kg				*3,800	*3,800	*3,350	2,450	*2,350	2,250	6.3	
3	kg		*6,150	*6,150	*4,500	3,650	*3,800	2,400	*2,000	1,900	6.9	
1.5	kg		*8,450	5,950	*5,350	3,400	*4,150	2,300	*2,550	1,850	7.0	
0	kg		*7,200	5,600	*5,850	3,200	*4,350	2,200	*2,400	1,800	6.9	
-1.5	kg	*5,150	*5,150	*8,600	5,550	*5,800	3,150	*4,200	*2,150	*2,800	2,000	6.4
-3	kg	*9,150	*9,150	*7,150	*5,650	*4,900	3,150		*3,750	*2,500	5.4	

Blade Up

B/A (m)	1.5		3.0		4.5		6		MAX REACH			
	Cf	Cs	Cf	Cs	Cf	Cs	Cf	Cs	Cf	Cs	A (m)	
6	kg				*3,600	*3,600			*2,050	*2,050	5.4	
4.5	kg				*3,800	*3,800	*3,350	2,450	*2,350	2,250	6.3	
3	kg		*6,150	*6,150	*4,500	3,650	*3,800	2,400	*2,000	1,900	6.9	
1.5	kg		*8,450	5,950	*5,350	3,400	3,950	2,300	*2,550	1,850	7.0	
0	kg		*7,200	5,600	5,850	3,200	3,850	2,200	*2,400	1,800	6.9	
-1.5	kg	*5,150	*5,150	*8,600	5,550	5,750	3,150	3,800	*2,150	*2,800	2,000	6.4
-3	kg	*9,150	*9,150	*7,150	*5,650	*4,900	3,150		*3,750	*2,500	5.4	

SPECIFICATIONS 915FCR

Lifting capacity at the arm end without bucket.
For lifting capacity including bucket, weight of the bucket or the bucket with quick coupler must be deducted from the lifting capacities.
Lifting capacities are based on the machine standing on a firm, uniform supporting surface.



Rating over-front (Cf)



Rating over-side (Cs)

- Do not attempt to lift or hold any load that is greater than these rated values at their specified load radius and height. Weight of all accessories must be deducted from the above lifting capacities.
- The rated loads are in compliance with ISO 10567 Hydraulic Excavator Lift Capacity Rating Standard. They do not exceed 87% of hydraulic lifting capacity or 75% tipping load.
- Ratings at bucket lift hook.
- Lifting capacities are based on machine standing on level, firm and uniform ground.
- *Indicates the load is limited by hydraulic capacity rather than tipping capacity.
- Operator should be fully acquainted with the Operator's and Maintenance Instructions before operating this machine and rules for the safe operation of equipment should be adhered to at all times.

LIFTING CAPACITY (METRIC)

915FCR with 500 mm Shoes, MONO Boom, 2,900 mm Arm

Conditions

A: Load radius
B: Load point height
C: Lifting capacity rating
Cf: Rating loads over front
Cs: Rating loads over side or 360°

Boom length: 4,800 mm
Arm length: 2,900 mm
Shoes: 500 mm triple grouser shoes
Bucket: None
Counterweight: 3,500 kg
Blade: YES

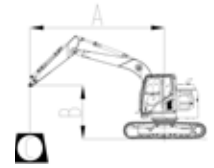

Blade Down

B/A (m)		1.5		3.0		4.5		6		MAX REACH		A (m)
		Cf	Cs	Cf	Cs	Cf	Cs	Cf	Cs	Cf	Cs	
6	kg					*3,200	*3,200			*1,700	*1,700	5.9
4.5	kg					*3,450	*3,450	*3,350	2,500	*1,650	*1,650	6.8
3	kg			*5,400	*5,400	*4,150	3,750	*3,600	2,450	*1,600	*1,600	7.3
1.5	kg			*7,900	6,150	*5,100	3,450	*4,000	2,300	*2,000	1,700	7.4
0	kg			*7,800	5,650	*5,750	3,250	*4,300	2,200	*1,950	1,700	7.3
-1.5	kg	*4,700	*4,700	*8,850	5,550	*5,850	3,150	*4,250	*2,150	*2,400	1,850	6.8
-3		*7,900	*7,900	*7,650	5,600	*5,250	3,150			*3,250	2,250	5.9
-4.5	kg			*5,050	*5,050					*3,100	*3,100	4.4

Blade Up

B/A (m)		1.5		3.0		4.5		6		MAX REACH		A (m)
		Cf	Cs	Cf	Cs	Cf	Cs	Cf	Cs	Cf	Cs	
6	kg					*3,200	*3,200			*1,700	*1,700	5.9
4.5	kg					*3,450	*3,450	*3,350	2,500	*1,650	*1,650	6.8
3	kg			*5,400	*5,400	*4,150	3,750	*3,600	2,450	*1,600	*1,600	7.3
1.5	kg			*7,900	6,150	*5,100	3,450	3,950	2,300	*2,000	1,700	7.4
0	kg			*7,800	5,650	*5,750	3,250	3,850	2,200	*1,950	1,700	7.3
-1.5	kg	*4,700	*4,700	*8,850	5,550	5,750	3,150	3,800	*2,150	*2,400	1,850	6.8
-3		*7,900	*7,900	*7,650	5,600	*5,250	3,150			*3,250	2,250	5.9
-4.5	kg			*5,050	*5,050					*3,100	*3,100	4.4

Lifting capacity at the arm end without bucket.
For lifting capacity including bucket, weight of the bucket or the bucket with quick coupler must be deducted from the lifting capacities.
Lifting capacities are based on the machine standing on a firm, uniform supporting surface.



Rating over-front (Cf)



Rating over-side (Cs)

- Do not attempt to lift or hold any load that is greater than these rated values at their specified load radius and height. Weight of all accessories must be deducted from the above lifting capacities.
- The rated loads are in compliance with ISO 10567 Hydraulic Excavator Lift Capacity Rating Standard. They do not exceed 87% of hydraulic lifting capacity or 75% tipping load.
- Ratings at bucket lift hook.
- Lifting capacities are based on machine standing on level, firm and uniform ground.
- *Indicates the load is limited by hydraulic capacity rather than tipping capacity.
- Operator should be fully acquainted with the Operator's and Maintenance Instructions before operating this machine and rules for the safe operation of equipment should be adhered to at all times.

LIFTING CAPACITY (METRIC)

915FCR with 600 mm Shoes, MONO Boom, 2,900 mm Arm

Conditions

A: Load radius
B: Load point height
C: Lifting capacity rating
Cf: Rating loads over front
Cs: Rating loads over side or 360°

Boom length: 4,800 mm
Arm length: 2,900 mm
Shoes: 600 mm triple grouser shoes
Bucket: None
Counterweight: 3,500 kg
Blade: YES

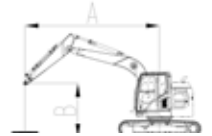

Blade Down

B/A (m)		1.5		3.0		4.5		6		MAX REACH		A (m)
		Cf	Cs	Cf	Cs	Cf	Cs	Cf	Cs	Cf	Cs	
6	kg					*3,200	*3,200			*1,700	*1,700	5.9
4.5	kg					*3,450	*3,450	*3,350	2,550	*1,650	*1,650	6.8
3	kg			*5,400	*5,400	*4,150	3,800	*3,600	2,450	*1,600	*1,600	7.3
1.5	kg			*7,900	6,250	*5,100	3,500	*4,000	2,350	*2,000	1,700	7.4
0	kg			*7,800	5,750	*5,750	3,300	*4,300	2,250	*1,950	1,700	7.3
-1.5	kg	*4,700	*4,700	*8,850	5,650	*5,850	3,200	*4,250	*2,200	*2,400	1,850	6.8
-3		*7,900	*7,900	*7,650	5,700	*5,250	3,200			*3,250	2,250	5.9
-4.5	kg			*5,050	*5,050					*3,100	*3,100	4.4

Blade Up

B/A (m)		1.5		3.0		4.5		6		MAX REACH		A (m)
		Cf	Cs	Cf	Cs	Cf	Cs	Cf	Cs	Cf	Cs	
6	kg					*3,200	*3,200			*1,700	*1,700	5.9
4.5	kg					*3,450	*3,450	*3,350	2,550	*1,650	*1,650	6.8
3	kg			*5,400	*5,400	*4,150	3,800	*3,600	2,450	*1,600	*1,600	7.3
1.5	kg			*7,900	6,250	*5,100	3,500	*4,000	2,350	*2,000	1,700	7.4
0	kg			*7,800	5,750	*5,750	3,300	3,900	2,250	*1,950	1,700	7.3
-1.5	kg	*4,700	*4,700	*8,850	5,650	5,850	3,200	3,850	*2,200	*2,400	1,850	6.8
-3		*7,900	*7,900	*7,650	5,700	*5,250	3,200			*3,250	2,250	5.9
-4.5	kg			*5,050	*5,050					*3,100	*3,100	4.4

SPECIFICATIONS 915FCR

Lifting capacity at the arm end without bucket.
For lifting capacity including bucket, weight of the bucket or the bucket with quick coupler must be deducted from the lifting capacities.
Lifting capacities are based on the machine standing on a firm, uniform supporting surface.



Rating over-front (Cf)



Rating over-side (Cs)

- Do not attempt to lift or hold any load that is greater than these rated values at their specified load radius and height. Weight of all accessories must be deducted from the above lifting capacities.
- The rated loads are in compliance with ISO 10567 Hydraulic Excavator Lift Capacity Rating Standard. They do not exceed 87% of hydraulic lifting capacity or 75% tipping load.
- Ratings at bucket lift hook.
- Lifting capacities are based on machine standing on level, firm and uniform ground.
- *Indicates the load is limited by hydraulic capacity rather than tipping capacity.
- Operator should be fully acquainted with the Operator's and Maintenance Instructions before operating this machine and rules for the safe operation of equipment should be adhered to at all times.

LIFTING CAPACITY (METRIC)

915FCR with 700 mm Shoes, MONO Boom, 2,900 mm Arm

Conditions

A: Load radius
B: Load point height
C: Lifting capacity rating
Cf: Rating loads over front
Cs: Rating loads over side or 360°

Boom length: 4,800 mm
Arm length: 2,900 mm
Shoes: 700 mm triple grouser shoes
Bucket: None
Counterweight: 3,500 kg
Blade: YES

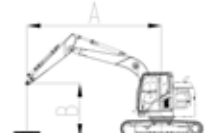

Blade Down

B/A (m)		1.5		3.0		4.5		6		MAX REACH		A (m)
		Cf	Cs	Cf	Cs	Cf	Cs	Cf	Cs	Cf	Cs	
6	kg					*3,200	*3,200			*1,700	*1,700	5.9
4.5	kg					*3,450	*3,450	*3,350	2,600	*1,650	*1,650	6.8
3	kg			*5,400	*5,400	*4,150	3,850	*3,600	2,500	*1,600	*1,600	7.3
1.5	kg			*7,900	6,350	*5,100	3,550	*4,000	2,400	*2,000	1,750	7.4
0	kg			*7,800	5,850	*5,750	3,350	*4,300	2,300	*1,950	1,750	7.3
-1.5	kg	*4,700	*4,700	*8,850	5,750	*5,850	3,250	*4,250	*2,250	*2,400	1,900	6.8
-3		*7,900	*7,900	*7,650	5,800	*5,250	3,250			*3,250	2,300	5.9
-4.5	kg			*5,050	*5,050					*3,100	*3,100	4.4

Blade Up

B/A (m)		1.5		3.0		4.5		6		MAX REACH		A (m)
		Cf	Cs	Cf	Cs	Cf	Cs	Cf	Cs	Cf	Cs	
6	kg					*3,200	*3,200			*1,700	*1,700	5.9
4.5	kg					*3,450	*3,450	*3,350	2,600	*1,650	*1,650	6.8
3	kg			*5,400	*5,400	*4,150	3,850	*3,600	2,500	*1,600	*1,600	7.3
1.5	kg			*7,900	6,350	*5,100	3,550	*4,000	2,400	*2,000	1,750	7.4
0	kg			*7,800	5,850	*5,750	3,350	3,950	2,300	*1,950	1,750	7.3
-1.5	kg	*4,700	*4,700	*8,850	5,750	*5,850	3,250	3,900	*2,250	*2,400	1,900	6.8
-3		*7,900	*7,900	*7,650	5,800	*5,250	3,250			*3,250	2,300	5.9
-4.5	kg			*5,050	*5,050					*3,100	*3,100	4.4

Lifting capacity at the arm end without bucket.
For lifting capacity including bucket, weight of the bucket or the bucket with quick coupler must be deducted from the lifting capacities.
Lifting capacities are based on the machine standing on a firm, uniform supporting surface.



Rating over-front (Cf)



Rating over-side (Cs)

- Do not attempt to lift or hold any load that is greater than these rated values at their specified load radius and height. Weight of all accessories must be deducted from the above lifting capacities.
- The rated loads are in compliance with ISO 10567 Hydraulic Excavator Lift Capacity Rating Standard. They do not exceed 87% of hydraulic lifting capacity or 75% tipping load.
- Ratings at bucket lift hook.
- Lifting capacities are based on machine standing on level, firm and uniform ground.
- *Indicates the load is limited by hydraulic capacity rather than tipping capacity.
- Operator should be fully acquainted with the Operator's and Maintenance Instructions before operating this machine and rules for the safe operation of equipment should be adhered to at all times.

LIFTING CAPACITY (METRIC)

915FCR with 500 mm Shoes, MONO Boom, 2,900 mm Arm

Conditions

A: Load radius
B: Load point height
C: Lifting capacity rating
Cf: Rating loads over front
Cs: Rating loads over side or 360°

Boom length: 4,800 mm
Arm length: 2,900 mm
Shoes: 500 mm rubber track shoes
Bucket: None
Counterweight: 3,500 kg
Blade: YES

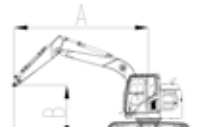

Blade Down

B/A (m)		1.5		3.0		4.5		6		MAX REACH		A (m)
		Cf	Cs	Cf	Cs	Cf	Cs	Cf	Cs	Cf	Cs	
6	kg					*3,200	*3,200			*1,700	*1,700	5.9
4.5	kg					*3,450	*3,450	*3,350	2,500	*1,650	*1,650	6.8
3	kg			*5,400	*5,400	*4,150	3,700	*3,600	2,400	*1,600	*1,600	7.3
1.5	kg			*7,900	6,100	*5,100	3,450	*4,000	2,300	*2,000	1,700	7.4
0	kg			*7,800	5,650	*5,750	3,200	*4,300	2,200	*1,950	1,700	7.3
-1.5	kg	*4,700	*4,700	*8,850	5,550	*5,850	3,100	*4,250	*2,150	*2,400	1,850	6.8
-3		*7,900	*7,900	*7,650	5,600	*5,250	3,100			*3,250	2,200	5.9
-4.5	kg			*5,050	*5,050					*3,100	*3,100	4.4

Blade Up

B/A (m)		1.5		3.0		4.5		6		MAX REACH		A (m)
		Cf	Cs	Cf	Cs	Cf	Cs	Cf	Cs	Cf	Cs	
6	kg					*3,200	*3,200			*1,700	*1,700	5.9
4.5	kg					*3,450	*3,450	*3,350	2,500	*1,650	*1,650	6.8
3	kg			*5,400	*5,400	*4,150	3,700	*3,600	2,400	*1,600	*1,600	7.3
1.5	kg			*7,900	6,100	*5,100	3,450	3,950	2,300	*2,000	1,700	7.4
0	kg			*7,800	5,650	*5,750	3,200	3,850	2,200	*1,950	1,700	7.3
-1.5	kg	*4,700	*4,700	*8,850	5,550	5,750	3,100	3,750	*2,150	*2,400	1,850	6.8
-3		*7,900	*7,900	*7,650	5,600	*5,250	3,100			*3,250	2,200	5.9
-4.5	kg			*5,050	*5,050					*3,100	*3,100	4.4

SPECIFICATIONS 915FCR

Lifting capacity at the arm end without bucket.
For lifting capacity including bucket, weight of the bucket or the bucket with quick coupler must be deducted from the lifting capacities.

Lifting capacities are based on the machine standing on a firm, uniform supporting surface.



Rating over-front (Cf)



Rating over-side (Cs)

- Do not attempt to lift or hold any load that is greater than these rated values at their specified load radius and height. Weight of all accessories must be deducted from the above lifting capacities.
- The rated loads are in compliance with ISO 10567 Hydraulic Excavator Lift Capacity Rating Standard. They do not exceed 87% of hydraulic lifting capacity or 75% tipping load.
- Ratings at bucket lift hook.
- Lifting capacities are based on machine standing on level, firm and uniform ground.
- *Indicates the load is limited by hydraulic capacity rather than tipping capacity.
- Operator should be fully acquainted with the Operator's and Maintenance Instructions before operating this machine and rules for the safe operation of equipment should be adhered to at all times.

LIFTING CAPACITY (METRIC)

915FCR with 500 mm Shoes, TWO-PIECE Boom, 2,500 mm Arm

Conditions

- A: Load radius
- B: Load point height
- C: Lifting capacity rating
- Cf: Rating loads over front
- Cs: Rating loads over side or 360°

Boom length: 5,050 mm
Arm length: 2,500 mm
Shoes: 500 mm triple grouser shoes
Bucket: None
Counterweight: 3,500 kg
Blade: None

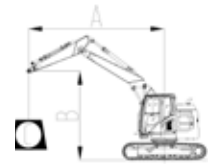

B/A (m)		1.5		3.0		4.5		6		MAX REACH		A (m)
		Cf	Cs	Cf	Cs	Cf	Cs	Cf	Cs	Cf	Cs	
6	kg					*3,650	*3,650			*2,050	*2,050	5.8
4.5	kg			*4,200	*4,200	*3,900	*3,900	*3,500	2,450	*2,050	2,050	6.7
3	kg			*6,550	*6,550	*4,550	3,650	*3,750	2,400	*2,050	1,750	7.2
1.5	kg					*5,300	3,350	3,850	2,250	*2,600	1,700	7.3
0	kg			*5,000	*5,000	*5,650	3,150	3,750	2,150	*2,450	1,700	7.2
-1.5	kg			*7,900	5,450	*5,450	3,050	3,700	*2,100	*3,000	1,850	6.7
-3	kg			*6,400	*5,600	*4,600	3,100			*3,100	*2,300	5.8

LIFTING CAPACITY (METRIC)

915FCR with 600 mm Shoes, TWO-PIECE Boom, 2,500 mm Arm

Conditions

- A: Load radius
- B: Load point height
- C: Lifting capacity rating
- Cf: Rating loads over front
- Cs: Rating loads over side or 360°

Boom length: 5,050 mm
Arm length: 2,500 mm
Shoes: 600 mm triple grouser shoes
Bucket: None
Counterweight: 3,500 kg
Blade: None

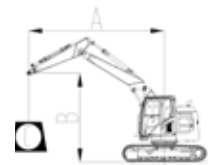

B/A (m)		1.5		3.0		4.5		6		MAX REACH		A (m)
		Cf	Cs	Cf	Cs	Cf	Cs	Cf	Cs	Cf	Cs	
6	kg					*3,650	*3,650			*2,050	*2,050	5.8
4.5	kg			*4,200	*4,200	*3,900	*3,900	*3,500	2,500	*2,050	*2,050	6.7
3	kg			*6,550	*6,550	*4,550	3,700	*3,750	2,400	*2,050	1,800	7.2
1.5	kg					*5,300	3,400	3,900	2,300	*2,600	1,700	7.3
0	kg			*5,000	*5,000	*5,650	3,200	3,800	2,200	*2,450	1,700	7.2
-1.5	kg			*7,900	5,550	*5,450	3,100	3,750	*2,150	*3,000	1,900	6.7
-3	kg			*6,400	*5,700	*4,600	3,150			*3,100	*2,300	5.8

Lifting capacity at the arm end without bucket.
For lifting capacity including bucket, weight of the bucket or the bucket with quick coupler must be deducted from the lifting capacities.

Lifting capacities are based on the machine standing on a firm, uniform supporting surface.



Rating over-front (Cf)



Rating over-side (Cs)

- Do not attempt to lift or hold any load that is greater than these rated values at their specified load radius and height. Weight of all accessories must be deducted from the above lifting capacities.
- The rated loads are in compliance with ISO 10567 Hydraulic Excavator Lift Capacity Rating Standard. They do not exceed 87% of hydraulic lifting capacity or 75% tipping load.
- Ratings at bucket lift hook.

- Lifting capacities are based on machine standing on level, firm and uniform ground.
- *Indicates the load is limited by hydraulic capacity rather than tipping capacity.
- Operator should be fully acquainted with the Operator's and Maintenance Instructions before operating this machine and rules for the safe operation of equipment should be adhered to at all times.

LIFTING CAPACITY (METRIC)

915FCR with 700 mm Shoes, TWO-PIECE Boom, 2,500 mm Arm

Conditions

- A: Load radius
- B: Load point height
- C: Lifting capacity rating
- Cf: Rating loads over front
- Cs: Rating loads over side or 360°

- Boom length: 5,050 mm
- Arm length: 2,500 mm
- Shoes: 700 mm triple grouser shoes
- Bucket: None
- Counterweight: 3,500 kg
- Blade: None

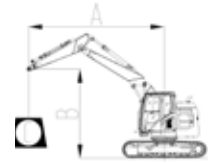

B/A (m)	1.5		3.0		4.5		6		MAX REACH		A (m)
	Cf	Cs	Cf	Cs	Cf	Cs	Cf	Cs	Cf	Cs	
6	kg				*3,650	*3,650			*2,050	*2,050	5.8
4.5	kg		*4,200	*4,200	*3,900	*3,900	*3,500	2,550	*2,050	*2,050	6.7
3	kg		*6,550	*6,550	*4,550	3,750	*3,750	2,450	*2,050	1,850	7.2
1.5	kg				*5,300	3,450	4,000	2,350	*2,600	1,750	7.3
0	kg		*5,000	*5,000	*5,650	3,250	3,850	2,250	*2,450	1,750	7.2
-1.5	kg		*7,900	5,700	*5,450	3,200	3,850	*2,200	*3,000	1,900	6.7
-3	kg		*6,400	*5,800	*4,600	3,250			*3,100	*2,350	5.8

LIFTING CAPACITY (METRIC)

915FCR with 500 mm Shoes, TWO-PIECE Boom, 2,500 mm Arm

Conditions

- A: Load radius
- B: Load point height
- C: Lifting capacity rating
- Cf: Rating loads over front
- Cs: Rating loads over side or 360°

- Boom length: 5,050 mm
- Arm length: 2,500 mm
- Shoes: 500 mm rubber track shoes
- Bucket: None
- Counterweight: 3,500 kg
- Blade: None

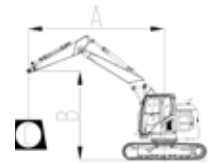

B/A (m)	1.5		3.0		4.5		6		MAX REACH		A (m)
	Cf	Cs	Cf	Cs	Cf	Cs	Cf	Cs	Cf	Cs	
6	kg				*3,650	*3,650			*2,050	*2,050	5.8
4.5	kg		*4,200	*4,200	*3,900	*3,900	*3,500	2,450	*2,050	2,000	6.7
3	kg		*6,550	*6,550	*4,550	3,650	*3,750	2,350	*2,050	1,750	7.2
1.5	kg				*5,300	3,300	3,850	2,250	*2,600	1,700	7.3
0	kg		*5,000	*5,000	*5,650	3,100	3,750	2,150	*2,450	1,700	7.2
-1.5	kg		*7,900	5,450	*5,450	3,050	3,700	*2,100	*3,000	1,850	6.7
-3	kg		*6,400	*5,600	*4,600	3,100			*3,100	*2,250	5.8

SPECIFICATIONS 915FCR

Lifting capacity at the arm end without bucket.
For lifting capacity including bucket, weight of the bucket or the bucket with quick coupler must be deducted from the lifting capacities.
Lifting capacities are based on the machine standing on a firm, uniform supporting surface.



Rating over-front (Cf)



Rating over-side (Cs)

1. Do not attempt to lift or hold any load that is greater than these rated values at their specified load radius and height. Weight of all accessories must be deducted from the above lifting capacities.
2. The rated loads are in compliance with ISO 10567 Hydraulic Excavator Lift Capacity Rating Standard. They do not exceed 87% of hydraulic lifting capacity or 75% tipping load.
3. Ratings at bucket lift hook.
4. Lifting capacities are based on machine standing on level, firm and uniform ground.
5. *Indicates the load is limited by hydraulic capacity rather than tipping capacity.
6. Operator should be fully acquainted with the Operator's and Maintenance Instructions before operating this machine and rules for the safe operation of equipment should be adhered to at all times.

LIFTING CAPACITY (METRIC)

915FCR with 500 mm Shoes, TWO-PIECE Boom, 2,500 mm Arm

Conditions

A: Load radius
B: Load point height
C: Lifting capacity rating
Cf: Rating loads over front
Cs: Rating loads over side or 360°

Boom length: 5,050 mm
Arm length: 2,500 mm
Shoes: 500 mm triple grouser shoes
Bucket: None
Counterweight: 3,500 kg
Blade: YES

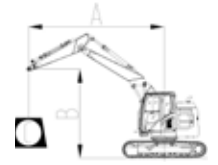

Blade Down

B/A (m)		1.5		3.0		4.5		6		MAX REACH		A (m)
		Cf	Cs	Cf	Cs	Cf	Cs	Cf	Cs	Cf	Cs	
6	kg					*3,650	*3,650			*2,050	*2,050	5.8
4.5	kg			*4,200	*4,200	*3,900	3,850	*3,500	2,450	*2,050	2,000	6.7
3	kg			*6,550	*6,550	*4,550	3,600	*3,750	2,350	*2,050	1,750	7.2
1.5	kg					*5,300	3,250	*4,000	2,200	*2,600	1,650	7.3
0	kg			*5,000	*5,000	*5,650	3,050	*4,200	2,100	*2,450	1,650	7.2
-1.5	kg			*7,900	5,350	*5,450	3,000	*4,000	*2,050	*3,000	1,800	6.7
-3	kg			*6,400	*5,500	*4,600	3,050			*3,100	*2,250	5.8

Blade Up

B/A (m)		1.5		3.0		4.5		6		MAX REACH		A (m)
		Cf	Cs	Cf	Cs	Cf	Cs	Cf	Cs	Cf	Cs	
6	kg					*3,650	*3,650			*2,050	*2,050	5.8
4.5	kg			*4,200	*4,200	*3,900	3,850	*3,500	2,450	*2,050	2,000	6.7
3	kg			*6,550	*6,550	*4,550	3,600	*3,750	2,350	*2,050	1,750	7.2
1.5	kg					*5,300	3,250	3,900	2,200	*2,600	1,650	7.3
0	kg			*5,000	*5,000	*5,650	3,050	3,750	2,100	*2,450	1,650	7.2
-1.5	kg			*7,900	5,350	*5,450	3,000	3,750	*2,050	*3,000	1,800	6.7
-3	kg			*6,400	*5,500	*4,600	3,050			*3,100	*2,250	5.8

Lifting capacity at the arm end without bucket.

For lifting capacity including bucket, weight of the bucket or the bucket with quick coupler must be deducted from the lifting capacities.

Lifting capacities are based on the machine standing on a firm, uniform supporting surface.



Rating over-front (Cf)



Rating over-side (Cs)

1. Do not attempt to lift or hold any load that is greater than these rated values at their specified load radius and height. Weight of all accessories must be deducted from the above lifting capacities.
2. The rated loads are in compliance with ISO 10567 Hydraulic Excavator Lift Capacity Rating Standard. They do not exceed 87% of hydraulic lifting capacity or 75% tipping load.
3. Ratings at bucket lift hook.
4. Lifting capacities are based on machine standing on level, firm and uniform ground.
5. *Indicates the load is limited by hydraulic capacity rather than tipping capacity.
6. Operator should be fully acquainted with the Operator's and Maintenance Instructions before operating this machine and rules for the safe operation of equipment should be adhered to at all times.

LIFTING CAPACITY (METRIC)

915FCR with 600 mm Shoes, TWO-PIECE Boom, 2,500 mm Arm

Conditions

- A: Load radius
- B: Load point height
- C: Lifting capacity rating
- Cf: Rating loads over front
- Cs: Rating loads over side or 360°

- Boom length: 5,050 mm
- Arm length: 2,500 mm
- Shoes: 600 mm triple grouser shoes
- Bucket: None
- Counterweight: 3,500 kg
- Blade: YES

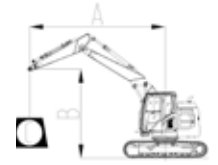

Blade Down

B/A (m)		1.5		3.0		4.5		6		MAX REACH		A (m)
		Cf	Cs	Cf	Cs	Cf	Cs	Cf	Cs	Cf	Cs	
6	kg					*3,650	*3,650			*2,050	*2,050	5.8
4.5	kg			*4,200	*4,200	*3,900	*3,900	*3,500	2,450	*2,050	2,050	6.7
3	kg			*6,550	*6,550	*4,550	3,650	*3,750	2,350	*2,050	1,750	7.2
1.5	kg					*5,300	3,350	*4,000	2,250	*2,600	1,700	7.3
0	kg			*5,000	*5,000	*5,650	3,100	*4,200	2,150	*2,450	1,700	7.2
-1.5	kg			*7,900	5,450	*5,450	3,050	*4,000	*2,100	*3,000	1,850	6.7
-3	kg			*6,400	*5,600	*4,600	3,100			*3,100	*2,250	5.8

Blade Up

B/A (m)		1.5		3.0		4.5		6		MAX REACH		A (m)
		Cf	Cs	Cf	Cs	Cf	Cs	Cf	Cs	Cf	Cs	
6	kg					*3,650	*3,650			*2,050	*2,050	5.8
4.5	kg			*4,200	*4,200	*3,900	*3,900	*3,500	2,450	*2,050	2,050	6.7
3	kg			*6,550	*6,550	*4,550	3,650	*3,750	2,350	*2,050	1,750	7.2
1.5	kg					*5,300	3,350	3,950	2,250	*2,600	1,700	7.3
0	kg			*5,000	*5,000	*5,650	3,100	3,850	2,150	*2,450	1,700	7.2
-1.5	kg			*7,900	5,450	*5,450	3,050	3,800	*2,100	*3,000	1,850	6.7
-3	kg			*6,400	*5,600	*4,600	3,100			*3,100	*2,250	5.8

SPECIFICATIONS 915FCR

Lifting capacity at the arm end without bucket.
For lifting capacity including bucket, weight of the bucket or the bucket with quick coupler must be deducted from the lifting capacities.
Lifting capacities are based on the machine standing on a firm, uniform supporting surface.



Rating over-front (Cf)



Rating over-side (Cs)

- Do not attempt to lift or hold any load that is greater than these rated values at their specified load radius and height. Weight of all accessories must be deducted from the above lifting capacities.
- The rated loads are in compliance with ISO 10567 Hydraulic Excavator Lift Capacity Rating Standard. They do not exceed 87% of hydraulic lifting capacity or 75% tipping load.
- Ratings at bucket lift hook.
- Lifting capacities are based on machine standing on level, firm and uniform ground.
- *Indicates the load is limited by hydraulic capacity rather than tipping capacity.
- Operator should be fully acquainted with the Operator's and Maintenance Instructions before operating this machine and rules for the safe operation of equipment should be adhered to at all times.

LIFTING CAPACITY (METRIC)

915FCR with 700 mm Shoes, TWO-PIECE Boom, 2,500 mm Arm

A: Load radius
B: Load point height
C: Lifting capacity rating
Cf: Rating loads over front
Cs: Rating loads over side or 360°

Conditions

Boom length: 5,050 mm
Arm length: 2,500 mm
Shoes: 700 mm triple grouser shoes
Bucket: None
Counterweight: 3,500 kg
Blade: YES

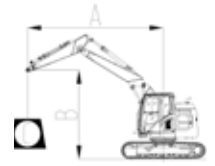

Blade Down

B/A (m)		1.5		3.0		4.5		6		MAX REACH		A (m)
		Cf	Cs	Cf	Cs	Cf	Cs	Cf	Cs	Cf	Cs	
6	kg					*3,650	*3,650			*2,050	*2,050	5.8
4.5	kg			*4,200	*4,200	*3,900	*3,900	*3,500	2,500	*2,050	2,050	6.7
3	kg			*6,550	*6,550	*4,550	3,700	*3,750	2,400	*2,050	1,800	7.2
1.5	kg					*5,300	3,400	*4,000	2,300	*2,600	1,700	7.3
0	kg			*5,000	*5,000	*5,650	3,200	*4,200	2,200	*2,450	1,700	7.2
-1.5	kg			*7,900	5,550	*5,450	3,100	*4,000	*2,150	*3,000	1,900	6.7
-3	kg			*6,400	*5,700	*4,600	3,150			*3,100	*2,300	5.8

Blade Up

B/A (m)		1.5		3.0		4.5		6		MAX REACH		A (m)
		Cf	Cs	Cf	Cs	Cf	Cs	Cf	Cs	Cf	Cs	
6	kg					*3,650	*3,650			*2,050	*2,050	5.8
4.5	kg			*4,200	*4,200	*3,900	*3,900	*3,500	2,500	*2,050	2,050	6.7
3	kg			*6,550	*6,550	*4,550	3,700	*3,750	2,400	*2,050	1,800	7.2
1.5	kg					*5,300	3,400	4,000	2,300	*2,600	1,700	7.3
0	kg			*5,000	*5,000	*5,650	3,200	3,900	2,200	*2,450	1,700	7.2
-1.5	kg			*7,900	5,550	*5,450	3,100	3,850	*2,150	*3,000	1,900	6.7
-3	kg			*6,400	*5,700	*4,600	3,150			*3,100	*2,300	5.8

Lifting capacity at the arm end without bucket.
For lifting capacity including bucket, weight of the bucket or the bucket with quick coupler must be deducted from the lifting capacities.
Lifting capacities are based on the machine standing on a firm, uniform supporting surface.



Rating over-front (Cf)



Rating over-side (Cs)

- Do not attempt to lift or hold any load that is greater than these rated values at their specified load radius and height. Weight of all accessories must be deducted from the above lifting capacities.
- The rated loads are in compliance with ISO 10567 Hydraulic Excavator Lift Capacity Rating Standard. They do not exceed 87% of hydraulic lifting capacity or 75% tipping load.
- Ratings at bucket lift hook.
- Lifting capacities are based on machine standing on level, firm and uniform ground.
- *Indicates the load is limited by hydraulic capacity rather than tipping capacity.
- Operator should be fully acquainted with the Operator's and Maintenance Instructions before operating this machine and rules for the safe operation of equipment should be adhered to at all times.

LIFTING CAPACITY (METRIC)

915FCR with 500 mm Shoes, TWO-PIECE Boom, 2,500 mm Arm

A: Load radius
B: Load point height
C: Lifting capacity rating
Cf: Rating loads over front
Cs: Rating loads over side or 360°

Conditions

Boom length: 5,050 mm
Arm length: 2,500 mm
Shoes: 500 mm rubber track shoes
Bucket: None
Counterweight: 3,500 kg
Blade: YES

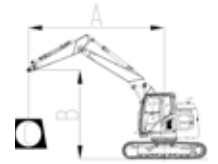

Blade Down

B/A (m)		1.5		3.0		4.5		6		MAX REACH		A (m)
		Cf	Cs	Cf	Cs	Cf	Cs	Cf	Cs	Cf	Cs	
6	kg					*3,650	*3,650			*2,050	*2,050	5.8
4.5	kg			*4,200	*4,200	*3,900	3,850	*3,500	2,400	*2,050	2,000	6.7
3	kg			*6,550	6,550	*4,550	3,550	*3,750	2,300	*2,050	1,750	7.2
1.5	kg					*5,300	3,250	*4,000	2,200	*2,600	1,650	7.3
0	kg			*5,000	*5,000	*5,650	3,050	*4,200	2,100	*2,450	1,650	7.2
-1.5	kg			*7,900	5,300	*5,450	3,000	*4,000	*2,050	*3,000	1,800	6.7
-3	kg			*6,400	*5,450	*4,600	3,050			*3,100	*2,200	5.8

Blade Up

B/A (m)		1.5		3.0		4.5		6		MAX REACH		A (m)
		Cf	Cs	Cf	Cs	Cf	Cs	Cf	Cs	Cf	Cs	
6	kg					*3,650	*3,650			*2,050	*2,050	5.8
4.5	kg			*4,200	*4,200	*3,900	3,850	*3,500	2,400	*2,050	2,000	6.7
3	kg			*6,550	6,550	*4,550	3,550	*3,750	2,300	*2,050	1,750	7.2
1.5	kg					*5,300	3,250	3,850	2,200	*2,600	1,650	7.3
0	kg			*5,000	*5,000	*5,650	3,050	3,750	2,100	*2,450	1,650	7.2
-1.5	kg			*7,900	5,300	*5,450	3,000	3,700	*2,050	*3,000	1,800	6.7
-3	kg			*6,400	*5,450	*4,600	3,050			*3,100	*2,200	5.8

STANDARD EQUIPMENT

ENGINE SYSTEM

913FCR

915FCR

- Cummins F3.8 engine, EU Stage V, turbocharged, 4 cylinder, 4 stroke, water cooled
- 3-power modes (Power, Standard, Economy)
- Engine overheat prevention system
- Engine oil low pressure protection
- Auto-idle speed control
- Automatic engine shutdown
- Twin-core air filter with integrated pre-filter
- Plastic fuel tank
- Manual fuel lifting pump
- Fuel pre-filter with water separator and water detection
- Remote engine oil filter
- Ground level engine oil guage
- Lockable engine oil guage
- Radiator dustproof net
- Air conditioner compressor belt automatic tense
- -20°C cold start capability

HYDRAULIC SYSTEM

913FCR

915FCR

- Full electric control hydraulic system
- Power boost function
- Pilot control shut-off lever
- Pilot accumulator
- Automatic swing parking brake
- Swing with anti-reverse function
- Automatic two-speed travel
- Automatic travel parking brake

OPERATOR STATION

913FCR

915FCR

- Pressurized and sealed cab
- ROPS certified cab
- Lower windshield can be removable
- Openable front windshield with assist device
- Large roof window with slide sliding sun visor
- Air suspension deluxe seat (with heater and head rest) +retractable seat belt (75 mm [3 in] width, red colour, with green alarm lamp)
- Consoles and seat height adjustable follow-up
- 8 inches high resolution LCD touch screen + integrated control panel
- Automatic air conditioner, heater, defroster
- Fire extinguisher
- Safety hammer for cab evacuation
- Green safety glass
- Cab interior lighting
- Left armrest box can be reversed

ELECTRICAL SYSTEM

913FCR

915FCR

- Monitor: working mode, working hour, water temperature, oil temperature, fuel level, DEF level, fuel consumption, rear vision, fault code, work condition etc. machine information.
- Warn: low engine oil pressure, low fuel level, air filter clog, machine overheat, low coolant level, low DEF level, maintenance remind etc.
- Two maintenance free battery
- Battery disconnect switch
- Front window wiper with time adjustable intermittent feature
- AM/FM radio with auxiliary input
- Blue tooth
- Working lights close time delay by programmable
- Cab interior decoration lights close time delay by programmable
- Ground level engine shutoff switch
- Set password for auxiliary hydraulic-flow adjustments
- Work tool flow and pressure programmable memories
- Control pattern-change valve

UNDERCARRIAGE

913FCR

915FCR

- Rollers, bottom - 7 each side
- Rollers, top - 1 each side
- Rollers, top - 2 each side
- 1 piece track guards (each side)
- Travel motor guards
- Centralized lubrication for swing bearing
- Towing eye on base frame
- Traction hole on base frame

UPPER STRUCTURE

913FCR

915FCR

- Punched metal anti-slip plates
- Foot pedal is in engine room
- Tool box
- Standard frame undercover
- One key for all locks
- 3000kg counterweight
- 500kg extra counterweight

—

—

DIGGING EQUIPMENT

913FCR

915FCR

- 4600mm boom
- Arm front end with guard bars
- Manual centralized lubrication on boom

—

SERVICE AND MAINTENANCE

913FCR

915FCR

- Maintenance tool kit
- Maintenance parts package
- Data diagnostic port
- Self-diagnostic system

OPTIONAL EQUIPMENT

ENGINE SYSTEM	913FCR	915FCR
<ul style="list-style-type: none"> • Electric refueling pump with auto shutoff 		
HYDRAULIC SYSTEM	913FCR	915FCR
<ul style="list-style-type: none"> • Boom and arm holding valves • Hand proportional control auxiliary dual way pipes • Hand proportional control auxiliary swing pipes • PTO max flow with manual control • Auxiliary sigle-double hydraulic lines exchange on the monitor • Auxiliary dual pipe flow & pressure adjustable • High pressure quick-coupler pipes • Low pressure quick-coupler pipes • Attachment oil drain line • Bucket cylinder rod protect 		
OPERATOR STATION	913FCR	915FCR
<ul style="list-style-type: none"> • Cab lower window guard • Cab top guard • Openable cab front guard • Cab front guard and top guard (falling object protective structure) • Sunscreen • Front window rain visor 		
ELECTRICAL SYSTEM	913FCR	915FCR
<ul style="list-style-type: none"> • Overload warning device • Travel alarm • Rotating beacon • Rotating warning light • Reserved installation seat and wiring harness for double warning lights in the cab • Quicker-coupler opening warning • Starting code • Right boom working light • Left boom working light • Right platform working light • Rear and right side view cameras • 360° view • Cab LED ceiling lights (2 in front) • Cab LED ceiling lights (4 in front and 2 in rear) 	<p>—</p> <p>—</p> <p>—</p> <p>—</p> <p>—</p> <p>—</p> <p>—</p> <p>—</p>	<p>—</p> <p>—</p> <p>—</p> <p>—</p> <p>—</p> <p>—</p> <p>—</p> <p>—</p>

• Work lights: long strip LED light in front and rear cab	—	
• Reserved installation seat and wiring harness for double warning lights in the cab		—
• Reserved installation seat and wiring harness for the long strip cab LED ceiling lights		
• 12V power supply		

UNDERCARRIAGE	913FCR	915FCR
----------------------	---------------	---------------

• Standard track undercover		
• Reinforced track undercover		
• 1 piece track guards (each side)	—	—
• 2 piece track guards (each side)	—	
• 500mm track-shoes with triple grousers		
• 600mm track-shoes with triple grousers		
• 700mm track-shoes with triple grousers and auxiliary track footrest		
• 500mm rubber block track		
• Dozer with locking function		
• Dozer with floating function	—	—

UPPER STRUCTURE	913FCR	915FCR
------------------------	---------------	---------------

• Guard fence of upper frame around		
• Standard frame undercover		—
• Reinforced frame undercover		
• 500kg extra counterweight		—

DIGGING EQUIPMENT	913FCR	915FCR
--------------------------	---------------	---------------

• Bucket linkage with lifting eye		
• Bucket lifting hole		
• Bucket cylinder rod protect	—	
• 2100mm short reach arm		
• 2500mm arm		
• 2900mm long reach arm		
• 4600mm boom	—	
• Two pieces boom	—	
• 0.5m³ standard bucket		—
• 0.55m³ standard bucket	—	
• Bucket thumbs		
• Bucket cylinder rod protect	—	





Guangxi LiuGong Machinery Co., Ltd.
No. 1 Liutai Road, Liuzhou, Guangxi 545007, PR China
T: +86 772 388 6124 E: overseas@liugong.com
www.liugong.com

Like and follow us:



LG-PB-913FCR_915FCR-Stage V-72-21072022-ENG

The LiuGong series of logos herein, including but not limited to word marks, device marks, letter of alphabet marks and combination marks, as the registered trademarks of Guangxi LiuGong Group Co., Ltd. are used by Guangxi LiuGong Machinery Co., Ltd. with legal permission, and shall not be used without permission. Specifications and designs are subject to change without notice. Illustrations and pictures may include optional equipment and may not include all standard equipment. Equipment and options varies by regional availability.