

## TECHNICAL SPECIFICATIONS ROCKWHEEL D20

The Hydraulic Cutting Unit Rockwheel D20 can be supplied with either scaling/grinding or rock cutting drums.

Hydraulic Power	70 kW
Maximum Oil Flow	320,0 l/min
Optimum Oil Flow	220,0 l/min
Maximum Pressure	400 bar
Cutter Torque	15.627 Nm @ 350 bar
Pick Force	48,4 kN @ 350 bar
Drum Speed	78,2 rpm @ 220 l/min
Pick Speed	2,6 m/s @ 220 l/min
Operating Weight	1.170 kg
Excavator Size	18 - 25 t
No. of Picks	64 [25,4 mm Shank]

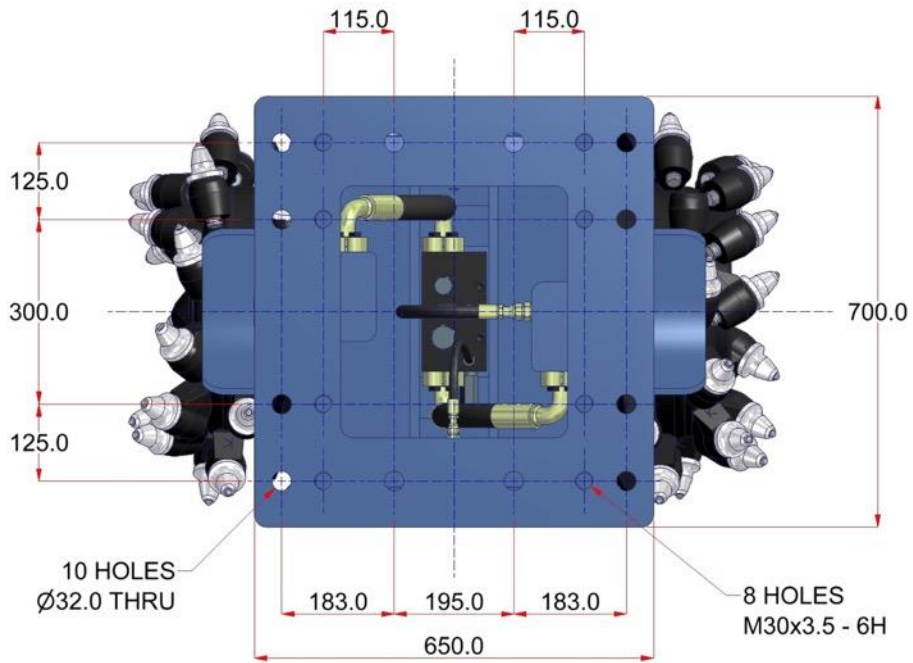

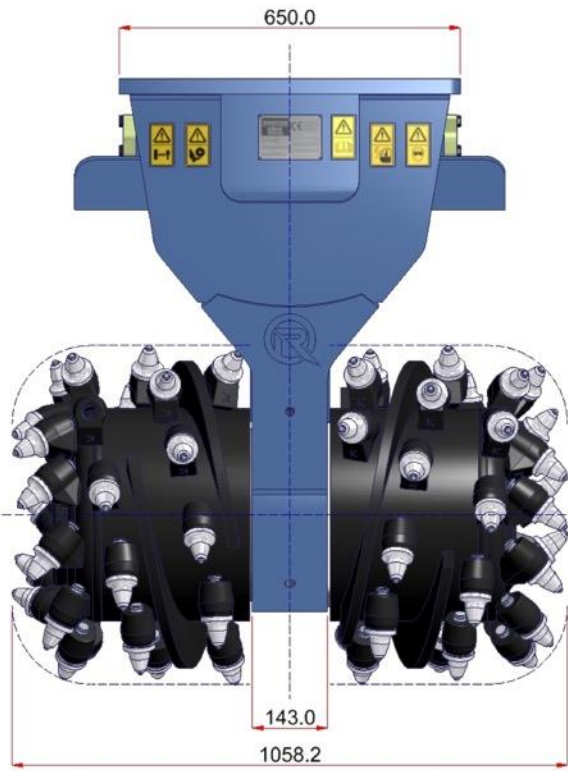
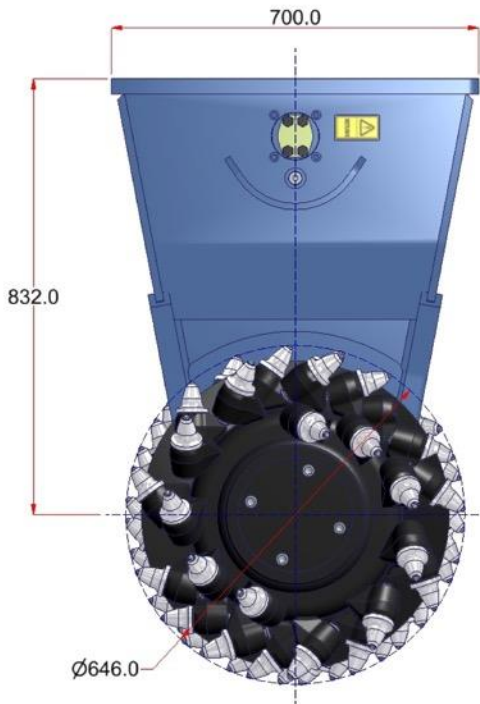

Rockwheel Cutting Units are designed and patented by Webster Technologies Ltd., UK.