

## TECHNICAL SPECIFICATIONS ROCKWHEEL C2

The Hydraulic Cutting Unit Rockwheel C2 is supplied with rock cutting drums.

Hydraulic Power	9,5 kW
Maximum Oil Flow	60,0 l/min
Optimum Oil Flow	30,0 l/min
Maximum Pressure	225 bar
Cutter Torque	1.095 Nm @ 225 bar
Pick Force	8,11 kN @ 225 bar
Drum Speed	98,0 rpm @ 30 l/min
Pick Speed	1,4 m/s @ 30 l/min
Operating Weight	66 kg
Excavator Size	0,7 - 2,5 t
No. of Picks (Rock Drums)	46 (14,0 mm Shank)

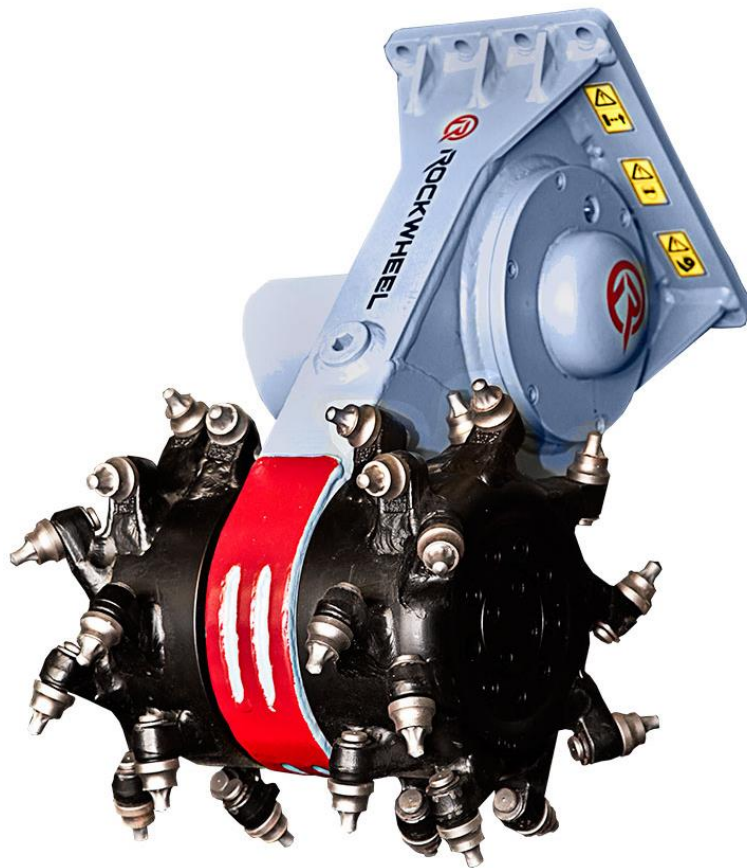

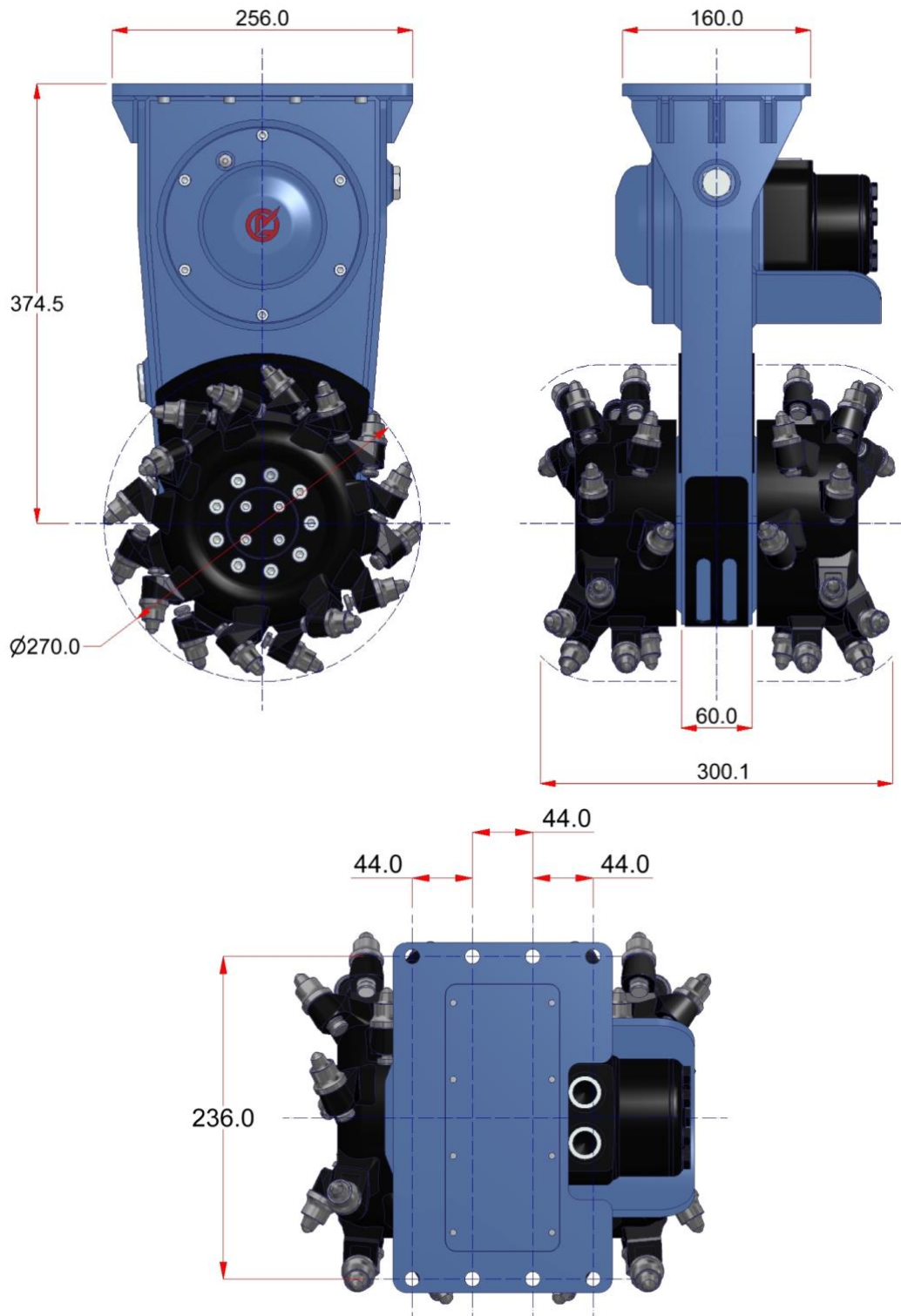

Rockwheel Cutting Units are designed and patented by Webster Technologies Ltd., UK.