



**FURUKAWA ROCK DRILL USA**  
*Rock Drill Division*

# **HCR1100-ER**



HCR1100-ER Equipped with Cummins® Tier-IV EPA Compliant Engine.

# Better penetration with i

The HCR1100-ER drill incorporates innovative features for higher output, capable of drilling at larger diameters. Utilizing a Cummins® Tier-IV EPA compliant engine, the HCR1100-ER combines higher performance with fuel efficiency.

## Higher output with the HD822 drifter.

The Furukawa HD822 drifter (patent applied for) is designed to minimize drill noise and vibration, while increasing performance. With 55% more impact and 28% more air flow than its predecessor, this drill has the ability to perform in harder rock at a larger diameter.

- New design increases percussion frequency by 20% versus the HD709 drifter.
- Dual dampening system stabilizes the bit against the rock, ensuring efficient energy transfer and straighter holes. The system automatically adjusts the drifter for maximum performance regardless of the rock condition.



## Improved operator control station complies with industry regulations.

The relocated control station keeps the operator away from drill rotation and dust from drilling.

- The improved electro-hydraulics allows easier operation.
- With FRD's TFSS (total fuel savings system), the operator selects the optimum engine speed for the application, allowing all fuel savings functions to be automatically managed during drilling operation.
- The monitoring system incorporates gauges next to the drilling station, allowing the operator a quick visual of engine temperature, hydraulic oil temperature and fluid levels.

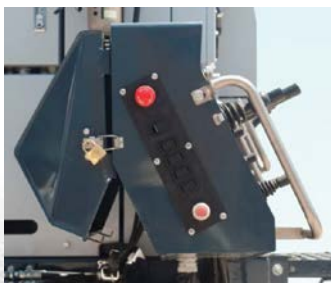

## Automatic Rod Changer.

Incorporates an automatic rod changer to eliminate the need for operators to manually install drill steel, resulting in increased production and enhanced operator safety.



## Upgraded Compressor.

- 275 cfm increases free air delivery by nearly 28% to accommodate larger diameter drilling.

# Increased impact

# HCR 1100-ER



Winch-ready frame.

## Innovative features for higher performance.

- Low emission, Tier-IV Cummins® engine meets strict North American exhaust emissions regulations.
  - Rod changer with proven design allows for the install of five drill steels plus one starter rod.
  - Winch-ready frame adds application versatility.
  - Optional wireless remote allows tramming and drilling from a secondary location.
- Also increases:
    - Impact rates up to 3,300 blows per minute.
    - Drifter power up to 29.5 HP.
    - Free air delivery up to 275 cfm.
    - Traction up to 19,700 lb-force.
    - Shoe width up to 13" (330 mm).
    - Dust collector capacity up to 918 cfm (26m³/min.).
    - Suction hose size up to 5" (125 mm).

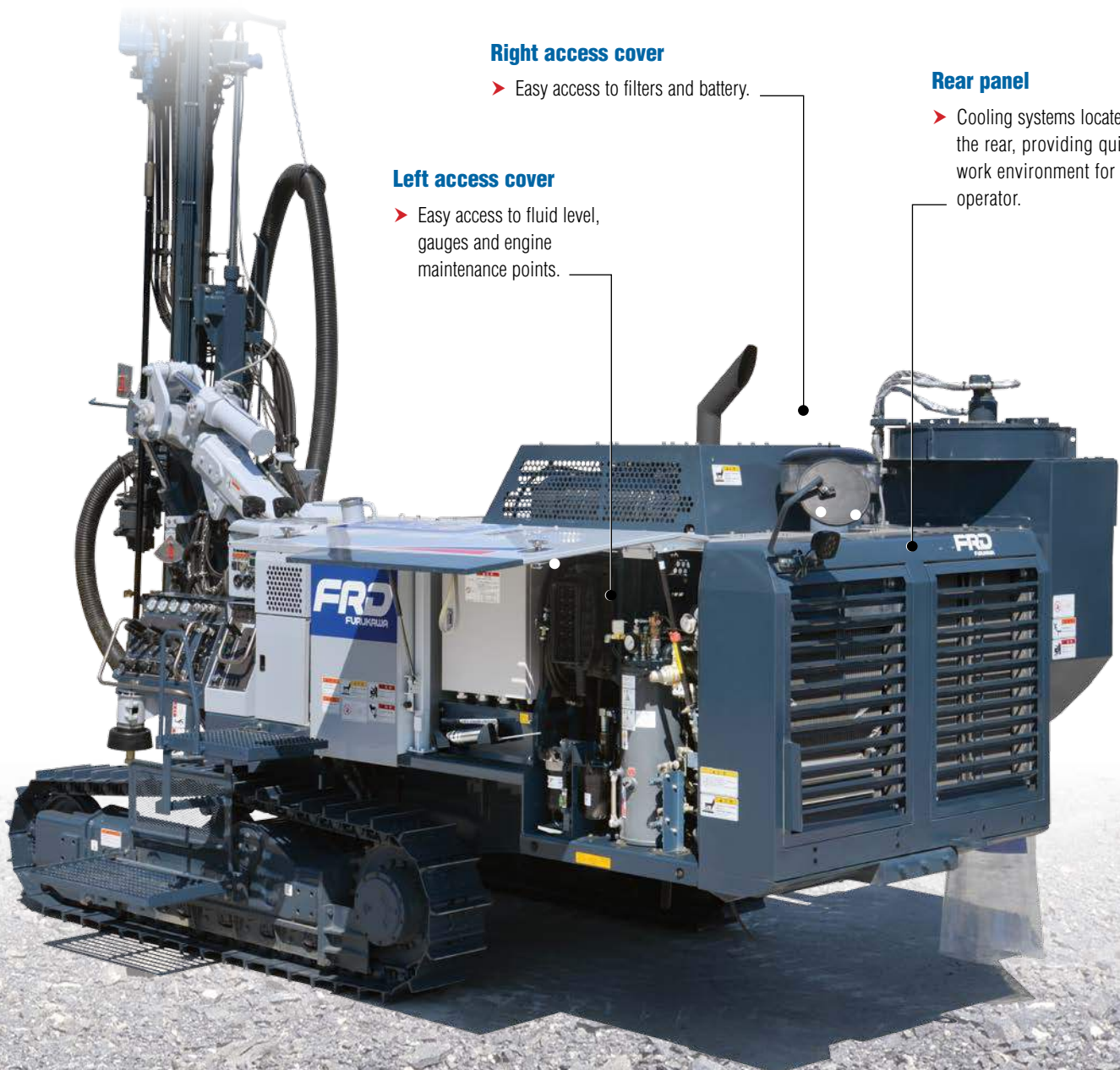

## Right access cover

- Easy access to filters and battery.

## Rear panel

- Cooling systems located in the rear, providing quieter work environment for the operator.

## Left access cover

- Easy access to fluid level, gauges and engine maintenance points.

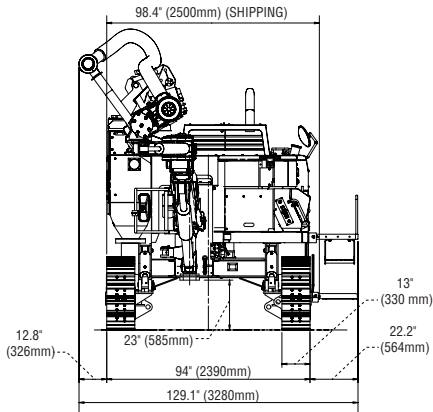
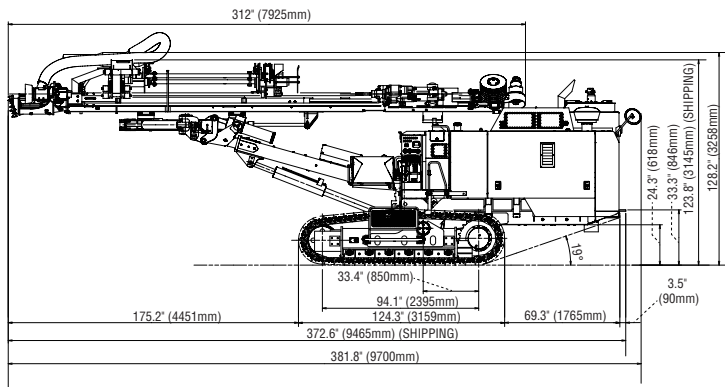
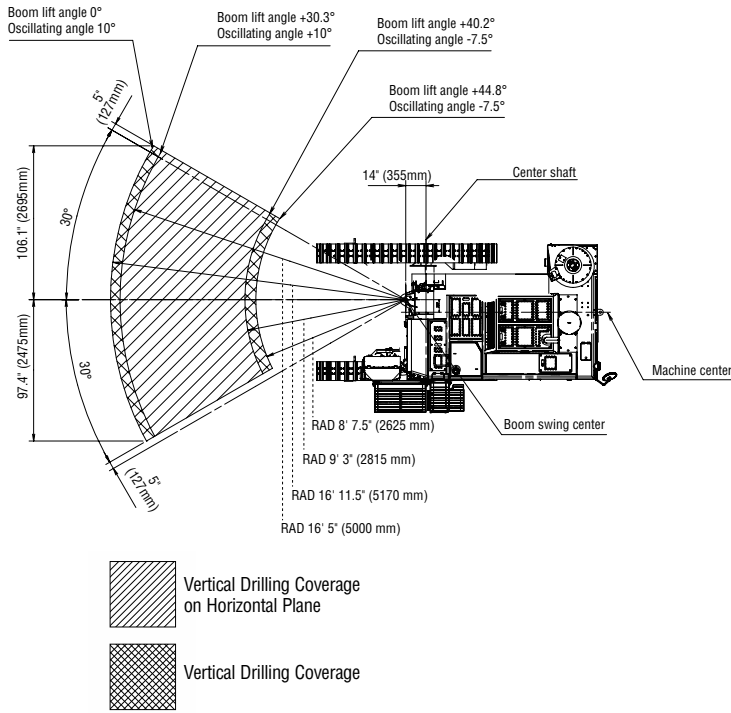

**FURUKAWA ROCK DRILL USA**

**Rock Drill Division**

805 Lake Street  
 Kent, Ohio 44240-0017  
 Phone: 800.358.4476  
 Fax: 330.673.8504  
 www.frdusa.com



HCR1100		ER	
		US Standard	Metric
General	Overall Weight (A) *1	27,500 lbs.	12,460 kg.
	Overall Weight (B) *2	28,000 lbs.	12,690 kg.
	Travel Speed	0 to 2 mph	0 to 3.2 km/h
	Maximum Traction Force	19,700 lb-force	88 kN
	Maximum Grade of Hill Climb	57.7% (30°)	
	Oscillating Angle	±7.6°	
	Ground Clearance	23"	585 mm
Ground Contact Pressure *3	11.2 psi	77.3 kPa	
Drifter	Model	HD 822	
	Operating Weight	533 lbs.	242 kg.
	Power	29.5 HP	22 kw
	Overall Length	44.5"	1,130 mm
	Overall Width	14.7"	373 mm
	Overall Depth	12.9"	328 mm
	Number of Blows	2,700 to 3,300 bpm	
Number of Revolutions	190 rpm	190 min <sup>-1</sup>	
Engine	Make & Model	Cummins® QSB6.7	
	Type	Water Cooled, 6-Cylinder Diesel Engine	
	Rated Output	226 HP/2200 rpm	168 Kw/2200 min <sup>-1</sup>
	Emission Control	Tier-IV Final	
Hydraulic Equipment	Variable Displacement Pump	Axial Piston Pump X2	
	Fixed Displacement Pump	Gear Pump X3	
	Drive Motor	Hydraulic Motor with Reduction Gear	
Boom	Model	JE326	
	Type	Extension Boom	
	Boom Lifting Angle: Up/Down	45°/15°	
	Boom Swing Angle: Right/Left	30°/30°	
	Boom Slide Length	3' 11"	1,200 mm
Guide Shell	Model	GH831	
	Overall Length	26' 0"	7,925 mm
	Feed Length	15' 8"	4,781 mm
	Guide Slide Length	3' 11"	1,200 mm
	Guide Swing Angle: Right/Left	30°/90°	
	Guide Tilt Angle	180°	
	Maximum Pulling Force	7,060 lb-force	31.4 kN
Feed System	Motor Chain		
Compressor	Make & Model	AIRMAN PDS265-S37C	
	Type	Screw 1-Stage	
	Discharge Airflow	275 cfm	7.8 m <sup>3</sup> /min
Dust Collector	Discharge Pressure	149 psi	1.03 Mpa
	Model	A844	
	Airflow	918 cfm	26 m <sup>3</sup> /min
	Number of Elements	5	
Rod Changer	Dust Removal System	Automatic Pulse Air Jet	
	Suction Cap	Slide Type	
	Number of Rods	5	
Electrical Equipment	Battery	12 Volt; 108Ah/5Hr	
	Voltage	DC 24V	
Fuel/Oil Capacity	Fuel Tank	84 US Gal	320 L
	Hydraulic Tank	45 US Gal	170 L
	DEF Tank *4	5 US Gal	19L
Bit and Rod	Bit Diameter	2.5" to 4"	64 mm to 102 mm
	Rod Size	T38 T45	
	Rod Length	10' or 12'	3,050 or 3,660 mm
	First Rod Length Maximum	13'	4,000 mm
Temperature	Operating Temperature	5° to 113° F	-15° to +45° C

Note:

- \*1 "Overall Weight (A)" includes weights of Fuel and Oils (full).
- \*2 "Overall Weight (B)" includes weights of Overall Weight (A), Operator and Full Rod Rock with Starter Rod.
- \*3 "Ground Contact Pressure" is calculated based on Overall Weight (A).
- \*4 DEF is an acronym for Diesel Exhaust Fuel (UREA Solution).

CUMMINS is a registered trademark of Cummins, Inc.

Furukawa's policy is one of continual improvement. Specifications may change between printing.