

1.5 Tonne Power Swivel

KEY FEATURES & BENEFITS - MACH2003



Market leading and the hirers favourite, the Thwaites 1.5 Tonne Power Swivel, Stage V dumper is the ideal machine when working in confined spaces or with limited access and is easily transported by trailer.

Powered by a 15.9 kW Yanmar engine, delivering 66.4 Nm of torque for optimum traction, this dumper is driven by a Hydrostatic Transmission making it very easy to operate.

The Power Swivel skip enables a 90° rotation left and right, allowing the machine easier access to tip loads in restricted areas, giving the operator greater control and reducing risk on site.

Easy to service and maintain with market leading residuals.

Safe, compliant and competitive.



Snap this QR code from your smart phone for more information



Thwaites

Thwaites Ltd, Leamington Spa,
Warwickshire, CV32 7NQ, England
Tel +44 (0)1926 422471

www.thwaitesdumpers.co.uk



GET THE JOB DONE.

1.5 Tonne Power Swivel

DIMENSIONS & SPECIFICATIONS - MACH2003

(mm)

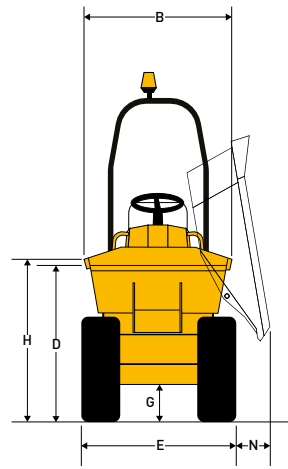
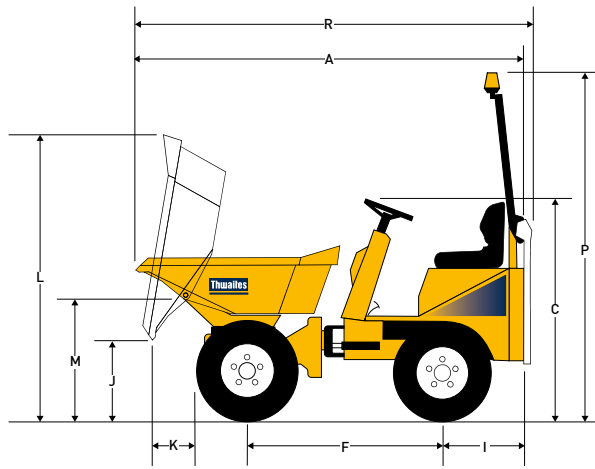

A	3097	N	177
B	1300	P	2860
C	1773	R	3257
D	1286		
E	1300		
F	1600		
G	274		
H	1328		
I	654		
J	651		
K	442		
L	2270		
M	901		

Weight	Unladen	1355 kg
	Shipping	1266 kg

Capacities	Max safe load	1500 kg
	Heaped	800 litres
	Struck	600 litres
	Water	520 litres

Engine

- › Yanmar 3TNV76, 3-cylinder, water-cooled diesel
- › Power 15.9 kW/21.4 bhp at 2800 rpm
- › Torque 66.4 Nm (49 lbf ft)

Noise Levels

- › Operator's ear 84 LpA / airborne level 101 LwA

Transmission

- › Hydrostatic with variable displacement pump feeding four wheel motors, incorporating "Twin-Lock" system to maximise traction

Speeds	Forward and Reverse	0 - 12 km/h (0 - 7.5 mph)

Brakes and Axles

- › Automatic failsafe braking system incorporated into rear drive motors

Chassis

- › Front and rear chassis constructed from folded steel plate, with centre-point articulation and oscillation for optimum stability and traction

Skip

- › Hydraulically operated, 4 mm base
- › Skip mouth reinforced with box sections
- › Power Swivel skip enables a 180° rotation

Seating & Controls

- › Adjustable suspension seat with high-vis seat belt
- › LED warning lights for all critical functions

Service Access

- › Lockable engine cover provides easy access from ground level to engine service points.

Electrics

- › Wiring harness contained within conduits
- › All electrical components water resistant to IP67 rating

Steering and Hydraulics

- › Hydraulic power steering
- › Return line filtration for all services
- › Hydraulic test point fitted as standard

Tank Capacities	Fuel	21 litres
	Hydraulic	20 litres

Turning Circle	6.00m

Standard Equipment

- › LED Beacons,
- › Reverse alarm

Optional Equipment

- › Road mirrors
- › Wheel nut indicator
- › Road lights
- › Towing bracket
- › Sand tyres

Thwaites

Thwaites Ltd, Leamington Spa,
Warwickshire, CV32 7NQ, England
Tel +44 (0)1926 422471

www.thwaitesdumpers.co.uk



Images are representative, but specific details or equipment may vary by country. We reserve the right to change any and all specifications without prior notice. 11/2021