

Muli T10 X, Muli T10 X HybridShift

**REFORM** **R**

The Transporter. The original.



**Muli premium class**

Multifunctional. Agile. Slope-capable.

**REFORM. Teamwork Technology.**



## REFORM Muli – The Universal Transporter

# Efficiency in all 4 seasons

REFORM transporters have been designed for universal application and for special purposes in the most diverse areas. They come with formidable terrain capability, maximum safety, and great comfort for operators and drivers. REFORM transporters have been produced in series since 1967.



By its versatile use, the REFORM Muli guarantees high utilisation all year round. Whether flat or steep, wet or dry – there is always something to do for the flexible transporter. The various attachment areas and versatile interfaces open up limitless applications for a Muli.

## REFORM Multi

# 4 full attachment areas

The chassis is designed for changeable attachments. Quick-change attachments such as tipper, self-loading trailer, winter service attachments, leaf vacuum, manure spreader, crane, deposit tipper and many more make the vehicle a compact and versatile work horse. REFORM Transporters feature 4 full attachment areas for a large range of tools and attachments.

- |          |   |  |
|----------|---|--|
| <b>1</b> | Main frame for top mounted attachments                    | 3-side tipper, self-loading trailer, deposit tipper, top mounted spreader, leaf vacuum, road brush, fire engine equipment, manure spreader, manure container |
| <b>2</b> | Front linkage/front mounting frame with/without front PTO | Snow plough, snow blower, rotary disc mower, twin blade mower, leaf suction/blower   |
| <b>3</b> | Platform frame behind the cab or at the rear end          | Loading crane, timber crane  |
| <b>4</b> | Rear linkage, trailer hitch with rear PTO                 | Various 3-point attachments and trailers   |





1 Road brush attachment



1 Loading wagon implement  
2 Rotary disc mower



1 3-side tipper with tank system  
2 Extension arm boom flail mower



1 3-side tipper  
3 Loading crane



1 Lateral spreader



1 Top mounted spreader  
2 Snow plough



1 Loading wagon implement

# VERSATILE

## Cutting edge technology and safety

# The REFORM Multi chassis

In the field or on the road, on snow or scree – The chassis concept of the REFORM transporters impresses with reliable technology and universal applications. Front and rear section are linked by a pivoting joint, forming the robust chassis on which a wide variety of attachments can be mounted.



**Lateral drive and front PTO (option)** The lateral drive can be used in 2 ways:

- Front PTO in combination with device mounting frame or front linkage
- Lateral PTO for operating special attachments.

With the 1,000 rpm front PTO, this drive unit is suited for a wide range of attachments.

- 2** The front **platform frame** is joined together with the engine, gearbox and front axle to form a fixed unit. This provides a solid carrier frame for the cab and the front attachment frame, which is used to mount various front attachments.
- 3** **Hydrostatic steering with Load Sensing and hydraulic synchronising cylinder.**  
No changed kinematics during spring deflection and rebound.  
Equal steering ratio in steering to the right and left.  
Increased ground clearance.

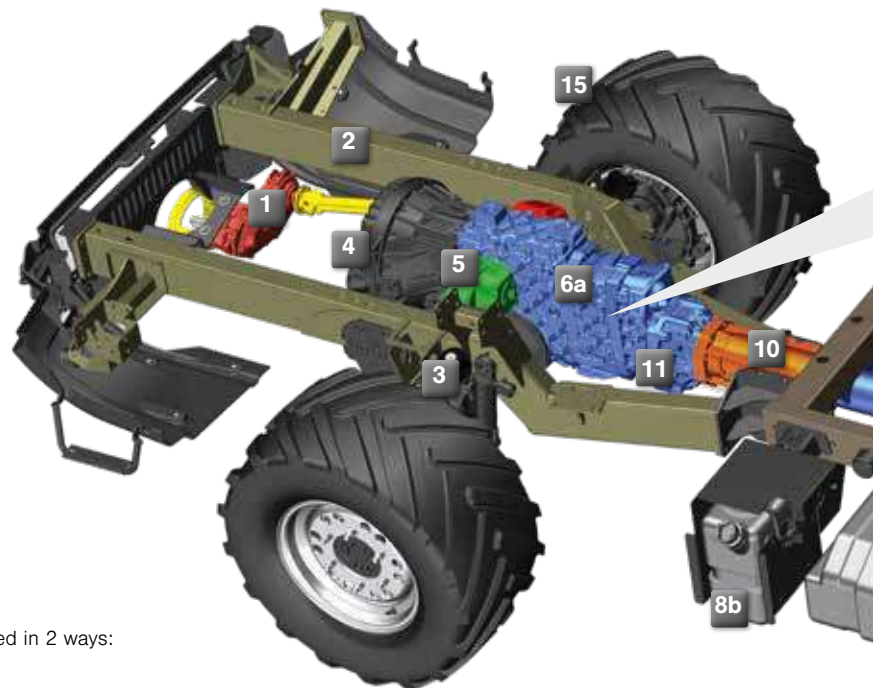

- 4** **Dual disc dry clutch** with separate actuation. **Drive clutch** hydraulic via pedal, electro-hydraulic **power shiftable PTO**;  
Multi T10 X HybridShift: In hydrostatic mode, the clutch pedal causes zero flow of the hydraulic pump.

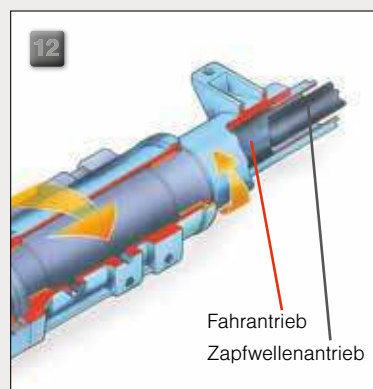
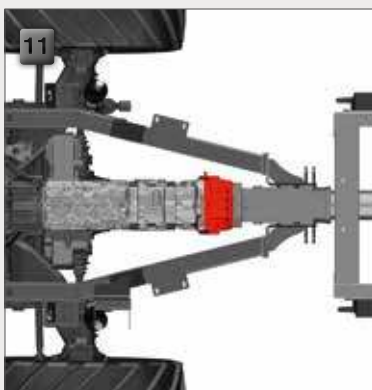

The lockable **centre differential (11)** is positioned between the front and rear axles and ensures, together with the permanent four wheel drive, maximum power transmission to the ground. Tensions between front and rear axle that could occur in cornering or uneven surfaces are compensated. If the centre differential is locked, the driving force is evenly distributed (1/1) between front and rear axles.

The **centre tube (12)** with integrated drive and PTO drive connects the shifting gearbox and the front axle gearbox with the rear axle. The axle drive and most of all also the PTO drive are directly routed to the rear, optimally protected by the centre tube (nothing can wind around the free propeller shaft). The PTO is tension-free twisted in the centre of the pivot joint, eliminating the need for pivot stop.

**5 Creep speed** (option for Muli T10 X)  
For attachments that require particularly low speeds (snow blower, mulcher, lateral manure spreader, etc.), a creep speed gearbox with 16 speed ranges is available from 0.4 kph.

**6 Direct shift shuttle gearbox** on Muli T10 X (6a)  
**Patented hybrid gearbox** on Muli T10 X HybridShift (6b)

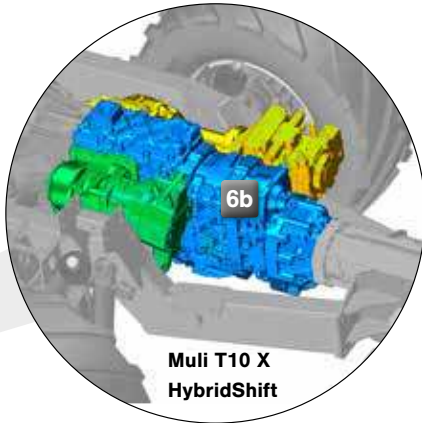

**7** The solid **main frame** is the mounting base for various attachments such as tipper, crane, top mounted spreader, leaf vacuum, etc. The attachments are mounted with quick releases such as anchor and eye bolts.

**8** The large 120-litre **PE tank (8a)** holds enough fuel for a whole working day without refuelling. Due to the 20-litre **AdBlue tank (8b)**, the Muli meets the current emission regulations and is ecologically clean on the road.

**9** The optionally available **auxiliary brake system** makes downhill driving even safer and less stressful. This wear-free eddy current brake relieves the main brake system and thus protects brake discs and pads.

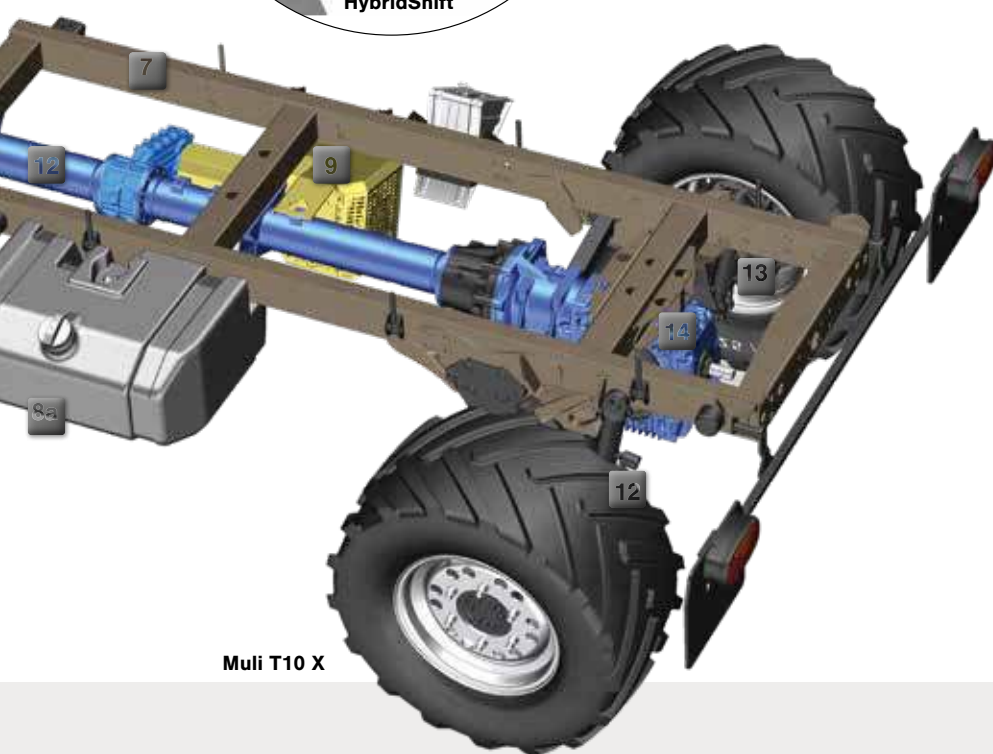

The 360° pivoting **central joint (10)** between front and rear axles makes sure that all 4 wheels have permanent ground contact, ensuring safe driving behaviour in any situation. It gives you full power transfer and optimum soil protection, even in rough terrain.



The front and rear axles are designed as **portal axles (13)**. This design provides the largest possible ground clearance with the corresponding passage width between the wheels. The ground clearance is 450 mm.

The centre tube with the propeller shafts for the rear wheel drive and for the **power shiftable rear PTO** ends in the robust **rear axle gearbox (14)**. There is no open cardan shaft between the main gearbox and the rear axle gearbox.

The standard **wheelhouse cover (15)** on the front axle protects the engine compartment. The full coverage prevents ingress of water and salt into the engine compartment.

## The suspension concept

# HCS High Comfort Suspension

## Independent suspension with level regulation

**Front axle suspension concept: CROSS SWITCH**

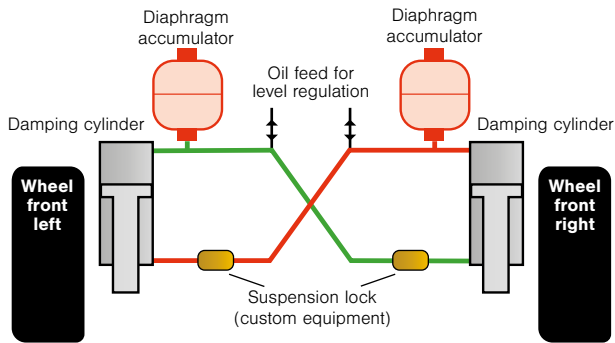

HCS High Comfort Suspension is a new suspension concept designed for demand-oriented driving comfort, which delivers highest comfort, stability and safety in any driving situation. The electronically controlled hydro-pneumatic suspension system with level regulation keeps the chassis always at the desired level, compensating for any payload. This produces exemplary suspension comfort, which protects the physical health of driver and passenger and also takes a lot of stress off the vehicle.

At the push of a button, the Muli can be raised or lowered, which makes mounting or removal of attachments such as tipplers much easier. A suspension lock can be activated for locking and lowering the selected axle. This lowers the vehicle's centre of gravity, making driving on rough terrain even safer.

**Rear axle suspension concept with counter pressure at the piston ring**

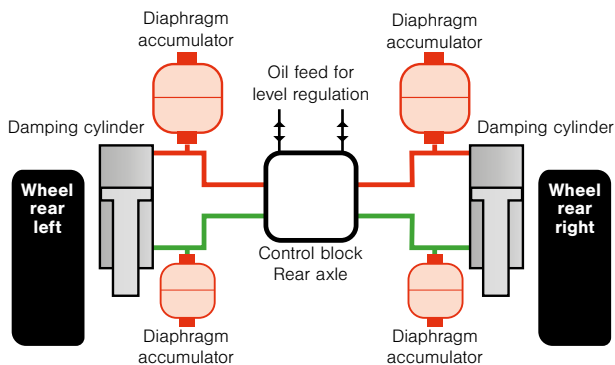

### Suspension principle of the portal axles

Independent suspension on trailing links via damping cylinders with hydraulic accumulators and elastic bump stops

- ① Diaphragm accumulators as elastic element
- ② Damping cylinder
- ③ Axle and wheel location

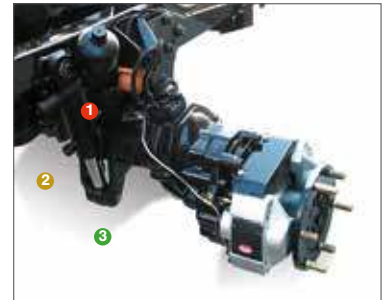

## Driving comfort with HCS (High Comfort Suspension)

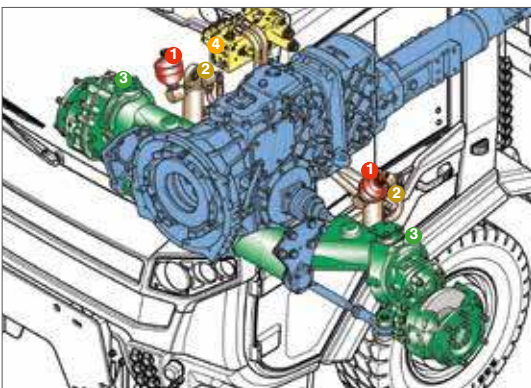

## 4 wheel steering

# The intelligent REFORM steering system

The unique REFORM 4 wheel steering system ensures highest manoeuvrability and can be switched to front or crab steering, thus providing 3 steering modes!

### These are the special features of original REFORM 4 wheel steering:

- Front and rear wheels are steered at the same angle and run exactly in the same track.
- Maximum soil protection by even, absolutely tension-free traction of all 4 wheels.
- Steering mode can be changed at the push of a button.
- “Smart” steering: sensors signal straight wheel alignment to the automatic steering system; fully automatic switching from front to 4 wheel steering and vice versa.
- 4 wheel steering recommended only up to 20 kph for safety reasons (warning signal sounds at higher speeds).

### Crab steering feature:

Front steering is used when the rear wheels are turned at an angle, which means that the Muli drives with lateral offset.

## The 3 steering modes

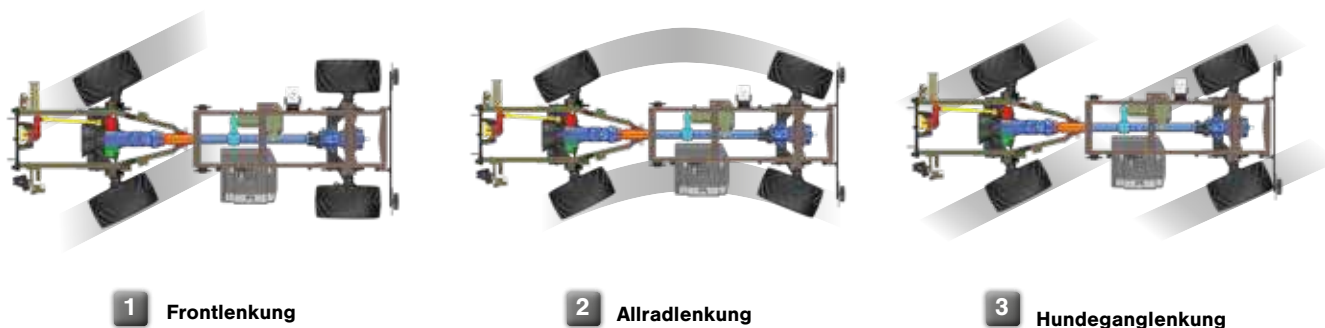

## REFORM – 4 wheel steering



### REFORM 4 wheel steering.

The steering modes can be switched conveniently by pressing a button on the dashboard of the Muli T10 X (1) or on the joystick of the Muli T10 X HybridShift (2). The steering switch status is indicated by symbols on the display.



## Maximum comfort

# The REFORM Muli cab

The REFORM Muli offers the driver an ergonomic workplace. In the development of the cab, emphasis was placed on creating large free spaces for driver and passenger. Comfortable seats, a 2-way adjustable steering column, pleasant air conditioning of the cab and excellent all-round view create perfect working conditions. A particularly low noise level, logical placement of all important controls, and great freedom of movement ensure relaxed working even during long periods of use.



A **perfectly cushioned seat** is easy on the back and increases comfort considerably. The various models offer the highest levels of comfort and safety. The driver and the passenger seat are optionally available with mechanical or air cushioning. The high backrest and the optional seat heater make work a pleasure.

## 2 Steering wheel adjustment

A correctly adjusted steering wheel is very important for a comfortable working position. The steering wheel of the Muli T10 X can be adjusted as standard vertically by +/- 50 mm as well as tilted by +/- 20 degrees.

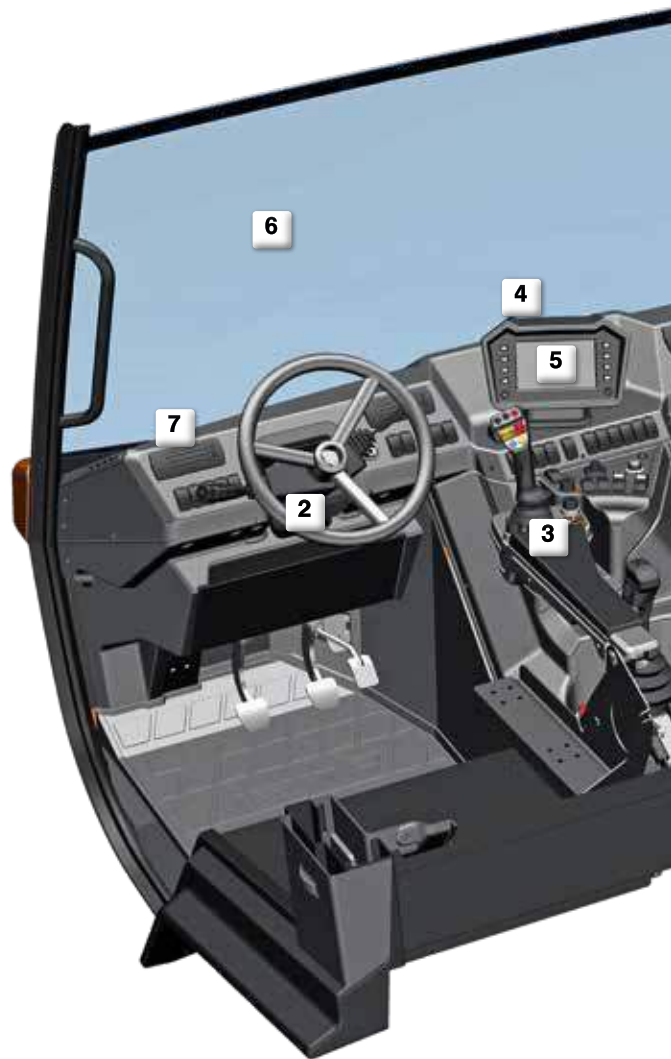

Many attachments have their own control unit or display (e.g. reversing camera). They can be ideally placed in the Muli cab by means of a specially developed **monitor holder (8)**. Cables between the attachment and control unit can be routed neatly and with a minimum of space into the cab through a cable lead-through in the tailboard. Pulse or power outlets for attachments are available as options.

In developing the cab, great emphasis was placed on ease of servicing. The **fuse box (9)** with all the main fuses is located centrally at the cab tailboard where it can always be reached with ease.

- 3 Ergonomic operation** of the individual functions. The logical layout of the controls facilitates work tremendously. So you always have everything under control and can concentrate fully on the job.



The **central information panel (4)** located in the centre of the cab shows the driver all the important information and data at a glance. By mounting it on the side, the view of the central information panel is not impaired by the steering wheel.



In addition to the central information panel, the Muli T10 X HybridShift has an integrated **operator control system (5)**. The driver can set the desired activity, and the operator control system suggests all the important settings of the vehicle.

- 6** The **panoramic windscreen** and the large rear window provide excellent visibility around the vehicle and of the attachments. This increases safety, simplifies working and maximises working comfort. The side windows and large-sized rear-view mirrors provide excellent visibility to the side and to the rear.
- 7** Year-round use of the Muli T10 X places high demands on the **air conditioning** of the cab. With the sophisticated cab design, the driver can look forward to a pleasantly cooled cab in summer and a nice warm workplace in winter. Differently arranged ventilation nozzles, a powerful fan and a large-sized air conditioner ensure a uniform distribution of air in the cab. On request, REFORM provides an electrically heated windscreen.



The **standard tilting cab (10)** of the Muli T10 X allows quick access to the engine compartment for maintenance and repairs. The cab can be raised in no time and hydraulically tilted to the side without tools. By tilting to the side, front attachments such as a mower or snow plough need not be removed.

For daily inspections, the **maintenance opening (11)** provides a quick and easy way to check the engine oil level, the water for the windscreen washer, the coolant, the clutch fluid, and the filters for the heater and air conditioner. Also any lamps can be replaced quickly through the maintenance opening.

## Perfect flexibility

# Always the right interface package

Whether hydraulic system, PTO, electrical interfaces – with the Muli T10 X and Muli T10 X HybridShift you are prepared for any job.

### Hydraulic system

In the REFORM Muli, a variety of hydraulic equipment is available to you. It can be individually adapted to the respective requirements.

### PTO

For attachments that are driven by the PTO, Muli T10 X and Muli T10 X HybridShift offer the possibility of front and rear PTO.

### Electrical system

Muli T10 X and T10 X HybridShift have all electrical interfaces such as various outlets and pulse sockets to a cable lead-through.

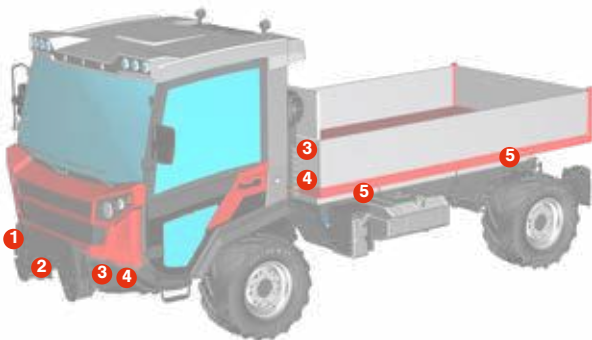

- 1) Front attachment plate/front linkage
- 2) Front PTO

- 3) Hydraulic system (front, centre, rear)
- 4) Electrical connectors (7, 13-pole, etc.)
- 5) Quick release system

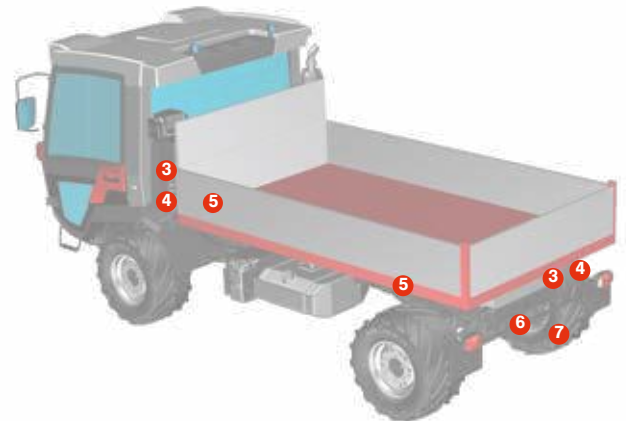

- 6) Rear PTO
- 7) Rear linkage, trailer hitch

## Hydraulic connections

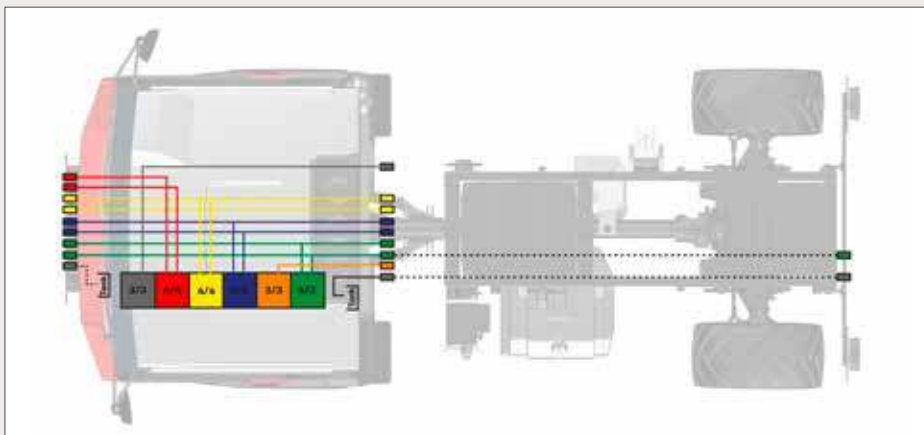

The front hydraulic system can be equipped with a 4-fold **multi-coupler**. This makes switching attachments even faster and easier.

The **hydraulic fittings** can be attached at the front, behind the cab or at the rear as needed.

## Maximum power

# Common-rail turbo-diesel engines

The powerful engines in the Muli T10 X excel by high torque, low fuel consumption and smooth running. The brawny 3-litre common-rail turbo engine produces 80 kW (109 hp) at 2,600 rpm and has a torque of 420 Nm even at a low engine speed of 1,110 rpm. This ensures optimum performance in all speed ranges and economic use of the vehicle.

### Emission level 5

The engine complies with the latest emission level 5. To meet the standard, Muli T10 X and T10 X HybridShift are equipped with self-regenerating particulate filters. The closed-loop diesel particulate filter system reduces soot emissions by over 98 %. The system also absorbs and eliminates 99.9 % of the particulate matter. For the sake of the environment, an oxidation catalytic converter is additionally installed.

The SCR equipment with AdBlue additive is used for exhaust gas treatment and reduces the emission of pollutants enormously. While driving, all sensors check the NOx and particulate levels.

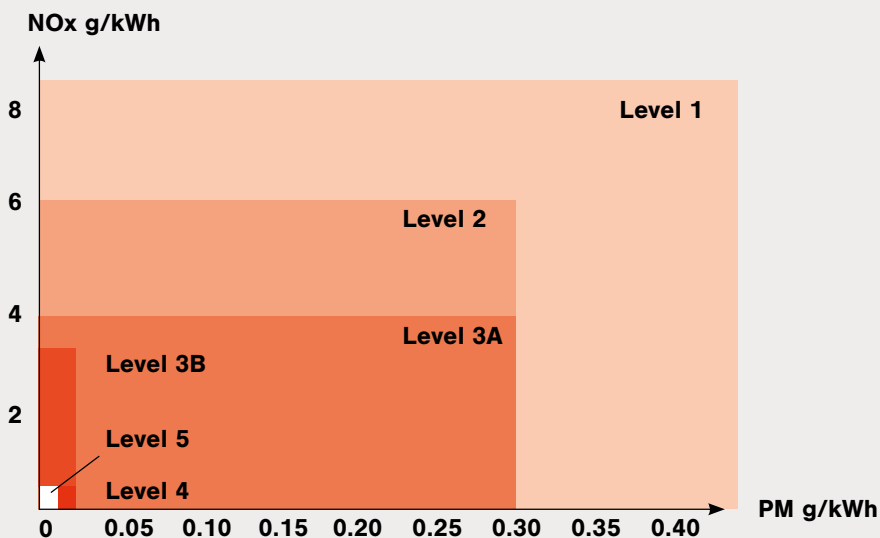
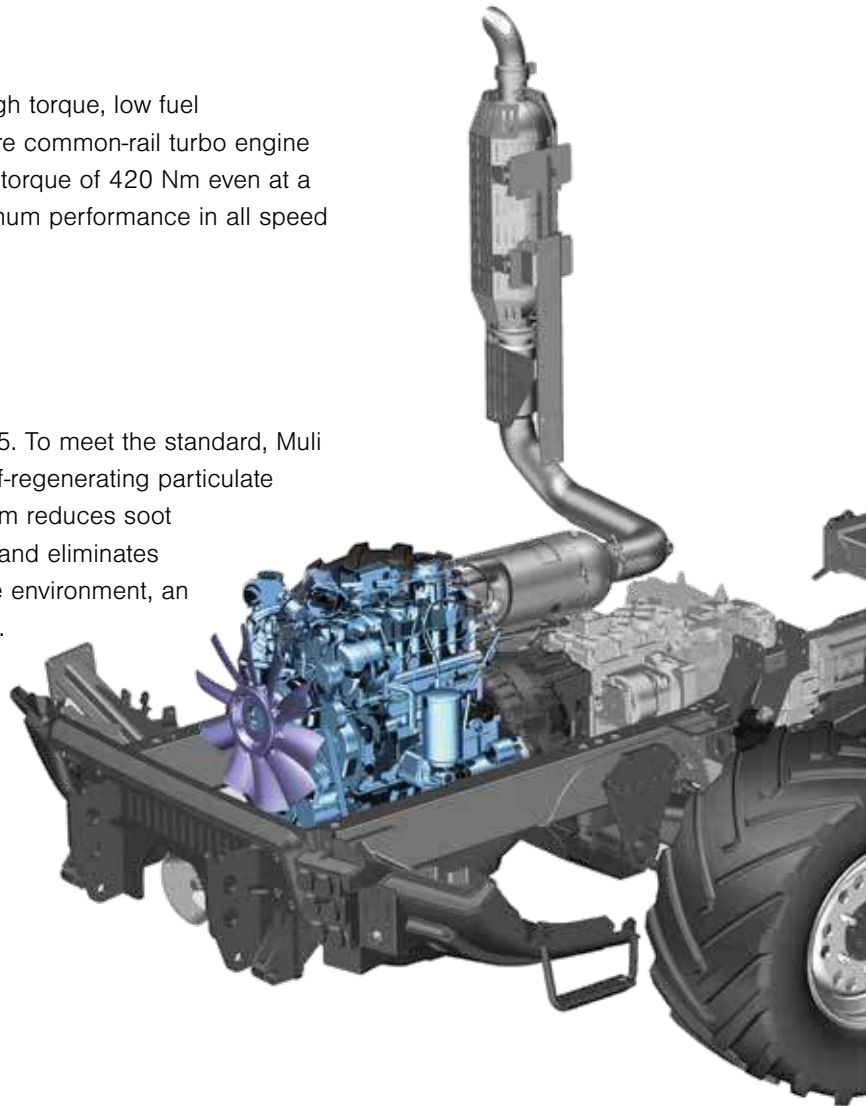

The more stringent emission stages reduce various pollutants in the exhaust gases of diesel engines.

- Carbon monoxide (CO)
- Hydrocarbon (HC)
- Nitrogen oxides (NOx)
- Particulate matter (PM)

Installing different exhaust gas treatment systems greatly reduces emissions of pollutants.

## REFORM Multi T10 X

# The versatile pro

A payload of up to 5,900 kg, greatest ground clearance, a very low dead weight and an extremely low centre of gravity make the Multi T10 X a versatile partner in mountain agriculture even in the most difficult and steepest terrain.



# The benefits at a glance

- Up to 5,900 kg payload
- Engine output 109 hp
- Tipping cab for easy servicing
- Generous front and rear windows
- Ergonomic comfort seats
- Central information panel with digital and analogue displays
- Optimised cab illumination in the entry area, LED search lighting in the roof liner
- Working hydraulics with Power Link system
- Hydrostatic steering with Load Sensing
- Retarder brake system for maximum safety

## Safe braking

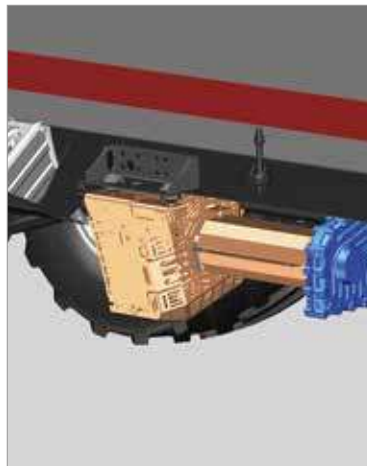
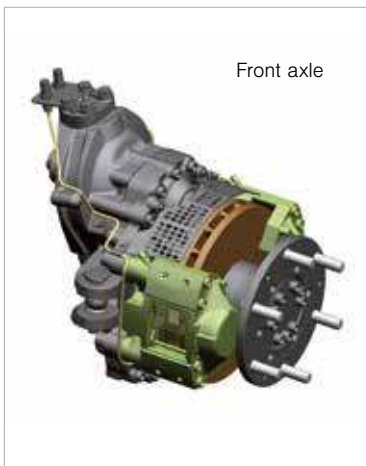

As standard, the Muli T10 X comes with **internally ventilated disc brakes** (front and rear). Braking efficiency is clearly increased by larger brake discs. Optimum heat dissipation is ensured by holes in the wheel rims. The dual-circuit, 4 wheel power brake is characterised by low pedal force and high braking power. The brake booster is also standard.

The wear-free auxiliary brake system supports the service brake and minimises the wear of the whole brake system. The activation of this **eddy current brake** is easy and convenient: the ergonomic hand lever is positioned directly next to the steering wheel and can be switched in steps. This also maximises safety on descents (no clutching or gear shifting required).

## The tried and tested trailing link suspension

### What is a trailing link suspension?

The spring deflection and rebound of the wheel is parallel to the direction of travel. This results in permanent **parallel ground contact** of the sprung driving wheel. Compact size and uncomplicated, robust design of the suspension make the use of portals (reduction gears) possible. The benefits of portals are obvious:

- Protection of the drivetrain
- Low tilting moment in the contour line
- Unparalleled ground clearance especially for driving over objects
- Ease of service

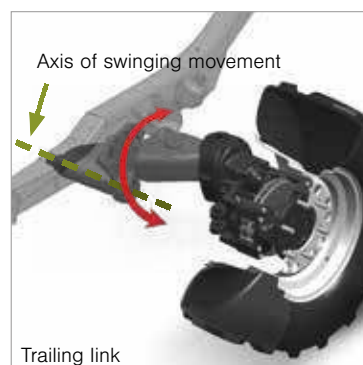

### Sprung axles with trailing links

Parallel wheel contact means in practice:

- Optimum grip in any situation
- Best possible tyre protection by even ground contact.
- Protects the turf in frequent passages
- Fewer open spots and gaps in the turf caused by damage.
- Lower risk of slipping
- Lower ground pressure
- Higher safety on slopes

## Muli T10 X

# The right speed for every task

REFORM Muli vehicles have a synchronised 40 kph or 50 kph splitting gearbox as standard equipment, in which the splitting group subdivides the 8 forward gears into 16 gears, creating an even finer speed stepping. For use in slow working mode, an optionally fitted stepped creep speed gearbox with 32 gears is available, which makes extremely slow driving possible

### Your benefits from the REFORM speed change gearbox:

- Narrow, even, field orientated gear stepping – well engineered and reliable
- Low moving-off speeds – essential for rough terrain
- 8 gears in the main working range between 4 and 12 kph
- Creep speed gear group with 16 creep speeds
- Large overlaps between the gears
- Smooth, quick and easy gear shifting with synchronised speed change and shuttle gearbox (provides also more safety on slopes)
- Short, exact shifting travels for precise gear selection and quick manoeuvring
- No Bowden cables (gear shift lever goes directly to the gearbox)
- Ergonomically placed and clearly arranged gear shift levers
- Preselectable splitting group for anticipatory shifting
- Simultaneous shifting (1–4) and splitting (I–II)
- Optimum working speed and PTO speed for maximum productivity of the attachments (e.g. rotary disc mower in front combined with top-mounted built-on self-loading trailer in the rear)
- Precision helical gearing, perfect match of engine, gearbox and drive ensure safety and long service life

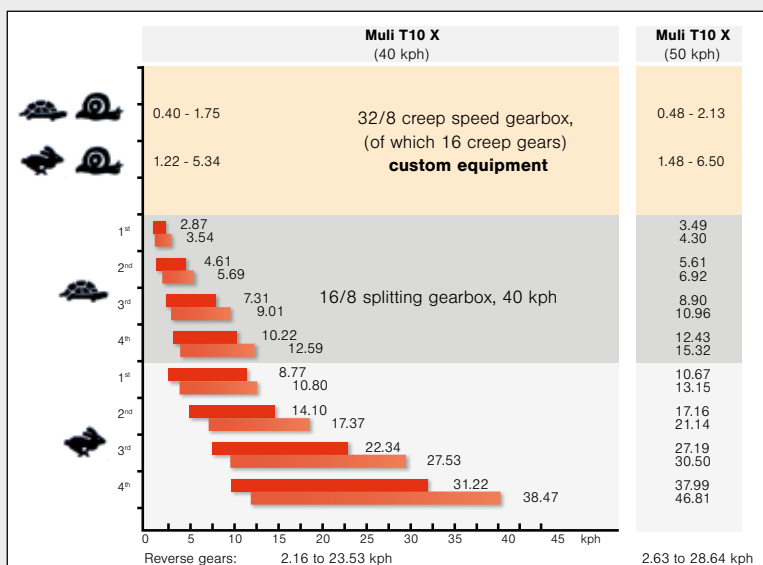

The gear shift levers are ergonomically placed next to the driver's seat. Thanks to the synchronisation of the speed change and shuttle gearbox, all gear changing operations can be performed quickly and easily.

Choose from:

- **16/8 splitting gearbox**
- **32/8 creep speed gearbox (option)**
- **Lateral drive (option)**

as an extension to the main gearbox, required for driving the front PTO.

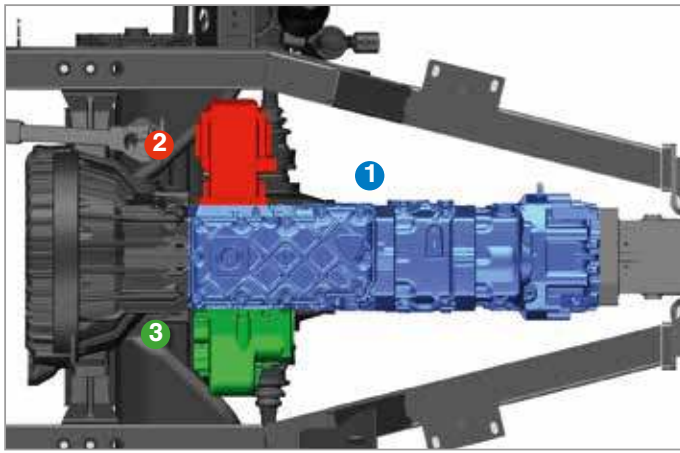

- 1 Main gearbox
- 2 Lateral drive (option)
- 3 Creep speed gears (option)

The 8 forward gears are subdivided at the **push of a button** into 16 gears by the splitting („half gear“) group, creating an even finer speed stepping.



# MULTITRAX

## Muli T10 X HybridShift

# The best of two worlds.

The demands on the Muli are becoming more diverse and require different drive concepts depending on the attachment, operating speed and load torque. Each drive concept has its advantages and disadvantages. The REFORM HybridShift gearbox, however, now makes it possible to combine the advantages of a hydrostatic drive in work mode and a mechanical drive in road mode without sacrifices.



### Mechanical drive

- Mechanical gearbox for road driving
- Economical due to high efficiency
- Unlimited applications
- Splitting at the push of a button (preselectable)

### Hydrostatic drive

- Eight-stage hydrostatic drive during work
- Comfort by continuous speed control
- Easy and ergonomic operation
- Changing the driving direction by pushing a button during work

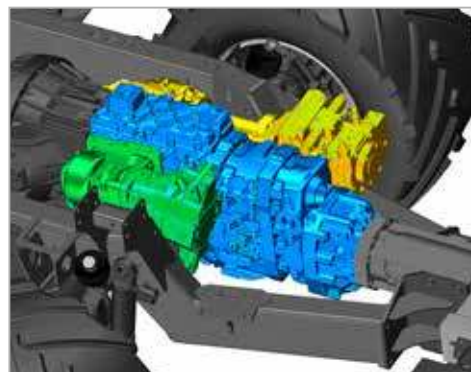

## Road

In road mode, nothing beats the efficiency of a mechanical transmission. Especially when fully loaded and in the high speed range, the vehicle can be operated economically.



---

## Working environment

The hydrostatic drive enables safe starting and stopping, even on extremely steep slopes, and thus brings the driver and vehicle through the workday unscathed.



Muli T10 X HybridShift

For each application  
the optimal drive



# Schaltgetriebe und stufenloses Getriebe



Depending on the work, the operator can choose between the speed change gearbox (1) and the continuously variable gearbox (2). Switching is done by a control lever.

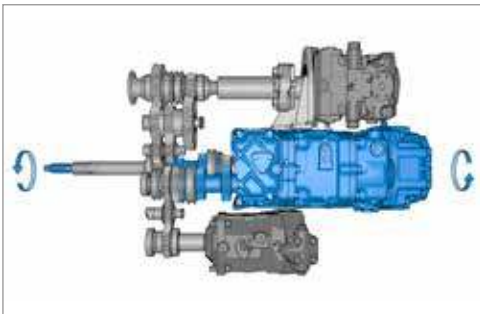

In mechanical mode, the hydraulic components are separated from the drivetrain. The drive is 100% mechanical (blue) without any loss of efficiency due to the hydraulic components.

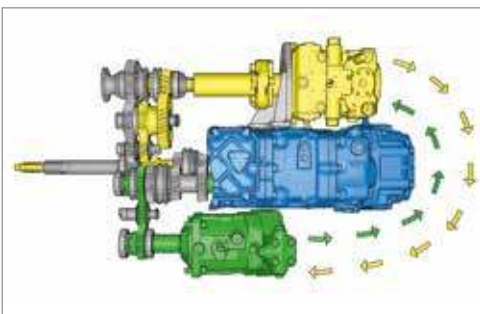

After changing to hydrostatic mode, the hydraulic components, hydro-pump (yellow) and hydro-motor (green), start to work. The hydrostat system can be controlled across 4 gears and two groups. The driving direction is changed via a rocker switch on the joystick.



# Driving speeds gearbox and hydrostat

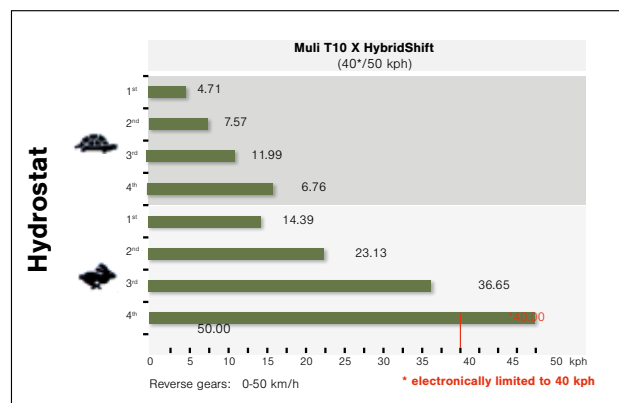
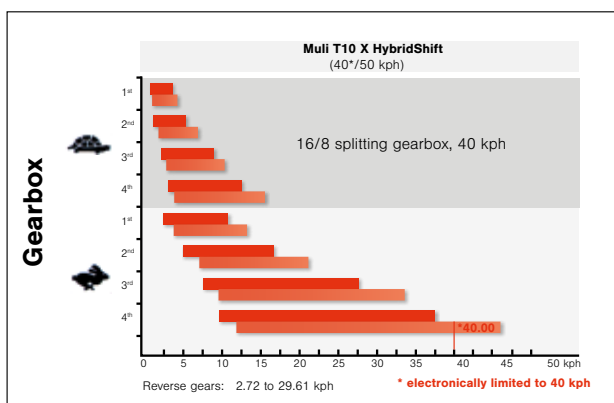



Mechanical drive for road driving ...





... hydrostatic drive for work



## TECHNOLOGY AT ITS BEST

# REFORM Assistance System (RAS)

Vehicles are becoming increasingly more complex in their functionality and operation. But to ensure that the operator is able to maintain an overview and fully concentrate on the work and the attachment, he is supported by the specially developed REFORM Assistance System (RAS).

### Funktionen REFORM Assistance System (RAS)



#### Cruise control

Automatically maintaining a constant preset driving speed, allowing the driver to fully concentrate on the attachment.



#### Speed limit

This allows more sensitive use of the accelerator pedal



#### Power limit control

Power limit control automatically controls the power distribution between the drive and the attachment drive.



#### PTO mode

In PTO mode, the driver can set a constant engine speed.



#### ECO mode

In continuous mode, this feature allows driving with optimised fuel consumption and low noise generation.



#### Operator control system

The heart of the REFORM Assistance System assists the operator in the optimal vehicle settings for different applications





## Areas of the operator control system

- 1 Gearbox:** The optimum gearbox and corresponding gear are suggested here
- 2 General vehicle:** The operator is suggested important vehicle settings for the specific work, such as suspension or cruise control, as well as any functional checks such as lighting, heater, etc.
- 3 Hydraulics and PTO info:** Here, required settings such as PTO on/off, PTO mode, or hydraulic settings such as weight compensation, are shown.
- 4 Work use:** A predefined work use can be selected here. Then, in the areas of gearbox, general vehicle, and hydraulics and PTO, the optimum setting for this selection is shown.

## Muli accessories

# Top equipment for any job



The device **mounting frame** allows front attachments to be directly mounted, e.g. snow plough or blower.



The **front 3 point linkage** with forks is available with electro-hydraulic weight compensation and vibration damping.



The **rear 3 point linkage** is equipped with fixed category 2 lower links.



**Rear trailer hitches** are available in various designs.



One or two **working lights** behind the cab provide sufficiently good visibility at night.



The **optical warning system** can be mounted on the roof of the Muli and can be labelled individually.



The roof of the Muli T10 X can accommodate up to 3 working lights per side or a **changeable lighting** for use with front attachment.



Make your working day a happier affair with music from a **stereo radio** with CD, USB, Bluetooth, and hands-free kit.



For individual requirements, **comfort seats** are available in different versions.



The splash-proof and lockable **tool box** made of polyethylene provides enough storage space for straps, tools or options.



All Muli models can be finished in your specified **custom paint**.



The **Recon wireless remote control** allows operating the attachments on the Muli T10X from the outside.

## Further accessories



For quick and easy connecting and disconnecting of the hydraulic hoses of front attachments, a **multi-hydraulic coupler (1)** can be installed.

Different control panels or monitors such as a **reversing camera (2)** with 5.6" colour monitor can easily be mounted on the **monitor holder (2)**.

### Other custom equipment

- Winter service preservation
- Bio-hydraulic oil
- Power outlets
- Tachograph

## Muli accessories

# The transporters with the strong profile

### Universal tyres



**15.0/55-17**  
AG profile



**425/55-R17**  
AG profile



**440/50 R17**  
All-Ground

The tried-and-tested special tread patterns ensure maximum traction, low ground pressure and reliable turf protection. They provide grip on difficult soils and on steep slopes.

### Auxiliary tyres Universal tyres



**7.50-18**  
front/rear



**285.80-R16**  
rear



**7.50-18**  
front/rear



**7.50-18**  
front/rear

Auxiliary tyres with universal tyres: Auxiliary tyres considerably increase slope suitability and soil protection – especially in moist soil conditions.

### Road tyres



**265/70 R19.5**



**285/70 R19.5**



**15.5/55 R18**



Innovative engineering since 1910

# Customer Satisfaction through Quality



REFORM-Werke Wels is one of the few manufacturers which assume undivided responsibility for the entire value added chain. Have a brief tour on the creation of Reform products, from development of a new machine to standard production. The entire production process is subject to the requirements of the ISO 9001 quality management system.



Latest equipment, such as 3D CAD, in **design and development** of new special purpose vehicles.



In **line assembly**, excellently trained and continuously schooled expert personnel produce a wide range of vehicle types and variants.



In **parts production** precision parts are manufactured on leading edge CNC tools in different batch sizes.



Before delivery, all vehicles undergo intensive **functional testing** such as here on the chassis dynamometer (pictured).



Permanent **quality control** ensures compliance with standards according to the ISO 9001 quality management system.



In **end of line check and finishing**, all machines are thoroughly checked once more and prepared for shipment to their future owners

PRODUCTION

# Abmessungen und Radaußenbreiten

## Dimensions Muli T10 X/ Muli T10 X HybridShift



### Dimensions in mm (tyres 15.0/55-17) REFORM built-on self-loading trailer REFORM tipper

Dimensions in mm (tyres 15.0/55-17)	REFORM built-on self-loading trailer	REFORM tipper
<b>A</b> Max. width exterior mirrors	2,650	2,650
<b>B</b> Max. width	PrimAlpin 2,470/MCLU 2,200	1,970 - 2,120
<b>C</b> Wheel outer width	2,045 FA, 2,030 RA	2,045 FA, 2,030 RA
<b>D</b> Height of roof top edge	2,355	2,355
<b>E<sup>1</sup></b> Height of hay top, folded in	PrimAlpin 2,375/MCLU 2,215	-
<b>E<sup>2</sup></b> Height of hay top, folded out	PrimAlpin 2,890/MCLU 2,830	-
<b>F</b> Height of PrimAlpin cross tube raised	3,140	-
<b>G</b> Height of cargo area	PrimAlpin 1,040/MCLU 990	1,060
<b>H</b> Length of axle/bumper	1,385	1,385
<b>I</b> Wheelbase	2,805/3,180	2,805/3,180
<b>J</b> Length of bumper/lamp holder	-	4,898/5,273
<b>K</b> Overall length	MCLU 6,155/6,530 PrimAlpin 6,520 + 70 with 4 wheel steering	5,217/5,591

## Wheel outer widths Muli T10 X/ T10 X HybridShift

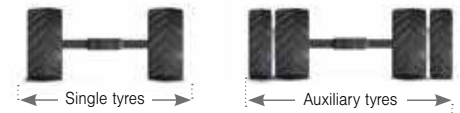

### Wheel outer widths (mm)

#### AG tyres front

15.0/55-17	2,045
15.0/55-17 w. aux. wheel 7.50-18	2,585
425/55 R17	2,110
425/55-R17 w. aux. wheel 7.50-18	2,585

#### AG tyres rear

15.0/55-17	2,030 / 2,045*
15.0/55-17 w. aux. wheel 7.50-18	2,565 / 2,585*
425/55 R17	2,090 / 2,150*
425/55-R17 w. aux. wheel 7.50-18	2,565 / 2,625*
425/55-R17 w. aux. wheel 285/80 R16	2,760 / -

#### All-Ground front tyres

440/50 R17	2,110
440/50-R17 w. aux. wheel 7.50-18	2,585

#### All-Ground rear tyres

440/50 R17	2,090 / 2,150*
440/50-R17 w. aux. wheel 7.50-18	2,565 / 2,625*

#### Road tyres front

15.5/55 R18	2,050
265/70 R19.5 (ET80)	2,040
265/70 R19.5 (ET120)	1,960
285/70 R19.5 (ET80)	2,080
285/70 R19.5 (ET120)	2,000

#### Road tyres rear

15.5/55 R18	2,035 / 2,050*
265/70 R19.5 (ET80)	2,025 / 2,040*
265/70 R19.5 (ET120)	1,945 / 1,960*
285/70 R19.5 (ET80)	2,060 / 2,080*
285/70 R19.5 (ET120)	1,980 / 2,000*

Wheel outer widths with all-wheel steering

# DATA

Technical data	Muli T10 X	Muli T10 X HybridShift
<b>Engine</b>		
Type	VM R754 EU6	VM R754 EU6
Power hp	109	109
Power kW	80	80
Displacement/cyl.	2,970	2,970
Cyl.	4	4
Torque	420	420
at engine speed	1,110	1,110
Nominal speed rpm	2,600	2,600
Emission level	5	5
Exhaust gas recirculation	✓	✓
DPF	✓	✓
SCR catalytic converter	✓	✓
Fuel tank, litres	120	120
AdBlue tank, litres	14	14
Electrical system	12 V/135 Ah	12 V/135 Ah
Alternator	180 A	180 A
<b>Drive/chassis</b>		
Dual disc dry clutch with separate actuation	✓	✓
Inching pedal	-	✓
Shuttle gearbox 16/8	✓	✓
Creep speed gearbox 32/8	o	-
"hydrostatic drive with 8 mechanical reductions"	-	✓
Speeds	40 or 50	40 or 50, hydrostatic 40 or 50
Driving/steering axles at front and drive axle at rear via portal axles	✓	✓
Driving/steering axle via front and rear portal axles	o	o
Permanent four wheel drive with switchable electro-hydraulic centre differential	✓	✓
100% electro-hydraulic rear differential lock	✓	✓
100% electro-hydraulic front differential lock	o	o
Hydropneumatic single wheel suspension at the front and rear axle via trailing arm	✓	✓
Front steering	✓	✓
Crab steering	o	o
4 wheel steering	o	o
Service brake: hydraulic dual-circuit four-wheel disc brakes on front and rear axle	✓	✓
Parking brake: Spring brake as sliding saddle disc brake, electro-hydraulic release	✓	✓
Wear-free brake retarder	o	o
<b>Tyre variants</b>		
15.0/55-17 AG	✓	✓
425/55 R17 AG profile	o	o
440/50 R17 All-Ground	o	o
265/70 R19.5 road tyres	o	o
15.5/55 R18 road tyres	o	o
285/70 R19.5 road tyres	o	o

Technical data	Muli T10 X	Muli T10 X HybridShift
<b>Cab</b>		
Tilting cab	✓	✓
Open cab with tinted windscreen and rear window	o	o
Closed cab with tinted all-round windows, doors with sliding windows and heating	✓	✓
Air-conditioning	✓	✓
Radio	o	o
Comfort seat leatherette, mechanically sprung with lap belt	✓	- / ✓
Comfort seat cloth cover, mechanically sprung with lap belt and high backrest	o	- / o
Comfort seat cloth cover, air cushioned with lap belt and high backrest	o	- / o
Comfort seat cloth cover, mechanically sprung with 3-point seat belt, high backrest and seat heater	o	✓ / o
Comfort seat cloth cover, air cushioned with 3-point seat belt, high backrest and seat heater	o	o
Changeable lighting	o	o
Front working light (1 - 3 pairs)	✓ / o / o	✓ / o / o
LED working light, front (1 - 3 pairs)	o / o / o	o / o / o
Rear working light	o	o
Rear LED working lights	o	o
LED rotating warning light	o	o
OWS	o	o
<b>Interfaces</b>		
Front attachment area optionally with mounting plate size 3 or front linkage cat. 1.	o	o
Lifting force front linkage kg	900	900
Rear linkage cat. 2	o	o
Lifting force kg	1,800	1,800
Hydraulic system: basic equipment l/min	42/o. 73	42/o. 73
bar	195/o. 240	195/o. 240
Control units: basic equipment	1 d.a.f./1 d.a.r./ 1 s.a.f./1 TR	1 d.a.f./1 d.a.r./ 1 s.a.f./1 TR
Control units: optional (maximum equipment)	3 d.a.f./1 d.a.r./ 2 s.a.f./1 TR	4 d.a.f./ 1 d.a.r./1 TR
<b>Hydraulic control</b>		
mechanical	✓	✓
proportional	o	o
Parallel lines, front/rear	o	o
<b>PTOs</b>		
Rear 540 rpm	✓	✓
Rear 1,000 rpm	o	o
Front 1,000 rpm	o	o
<b>Weights</b>		
Unladen weight as standard equipment	3,480	3,600
Front axle load (*dependent on tyres)	4,600/5,200*	4,600/5,200*
Rear axle load (*dependent on tyres)	4,600/5,200*	4,600/5,200*
Permissible total weight (*dependent on tyres)	9,000/9,500*	9,000/9,500*

Line	✓
Optional	o
not available	-

Illustrations partly show special equipment, technical changes and printing errors reserved.

# REFORM. Teamwork Technology.



PRO1211/0923

## **REFORM Austria**

Reform-Werke  
Bauer & Co Gesellschaft m.b.H.  
Haidestraße 40, A-4600 Wels  
Tel: +43 (0) 7242 / 232-0  
info@reform.at

## **REFORM Switzerland**

Agromont AG  
Bösch 1, CH-6331 Hünenberg  
Tel: +41 (0) 41 784 / 20 20  
info@agromont.ch  
www.agromont.ch

## **REFORM Germany**

Kiefer GmbH  
Mechanical Engineering, Vehicle  
Construction & Sales  
Furter Straße 1, D-84405 Dorfen  
Tel: +49 (0) 8081 / 414-0  
info@kiefergmbh.de

Illustrations partly show special equipment,  
technical changes and printing errors reserved.



[www.reform.at](http://www.reform.at)

# REFORM **R**