

17SK



Concrete solutions. Always.

Engine V2607-CR-T

Engine power 50,0 kW - 67,1 HP

Operating Weight 3.600 kg

 **EUROCOMACH**[®]

Operating weight	kg	3.600
------------------	----	-------

ENGINE		
Type	KUBOTA V2607-CR-T-STAGE 5	
Max. Power (2.600 rpm)	kW - HP	50,0 - 67,1
Max. torque (1.600 rpm)	Nm	225
Displacement	cc	2.615
Number of cylinders	n°	4
Cooling	Liquid	
Consumption	lt/h	11
Alternator	V (A)	12 (60)
Battery	V (Ah)	12 (100)

HYDRAULIC SYSTEM		
Pump type	n.1 with gears for services	
Pump capacity	lt/min	80
Max. circuit calibration pressure	bar	240
Auxiliary system:	Max. capacity	lt/min
	Max. pressure	bar
High Flow System (optional):	Max. capacity	lt/min
	Max. pressure	bar

TRANSMISSION		
Type	Hydrostatic with electro-hydraulic tandem pump and radial pistons REXROTH gearboxes	
Travelling speed	km/h	1a: 0 ÷ 9,0 / 2a: 0 ÷ 18,0
Traction force	daN	3.700
Dimensions tires	10 x 16,5	

BRAKES		
Service brakes	Hydrostatic	
Parking brakes	Negative with multiple disks into oil bath, integrated on the rear gearboxes at electrohydraulic control	
Emergency brakes	Electrohydraulic control, acting on parking brakes (integrated on the rear gearboxes)	

PERFORMANCES		
Tipping load (ISO 14397)	kg	1.960
Operating load (ISO 14397, no more than 50% of tipping load)	kg	980
Bucket breaking force	daN	2.900
Standard bucket capacity	m³	0,44
Standard bucket width	mm	1.715
Max. slope	60% - 30°	

FILLINGS		
Fuel tank	lt	85
Hydraulic oil tank	lt	35
Hydraulic circuit capacity	lt	50
Cooling system capacity	lt	12
Engine oil	lt	10,2

CONTROLS		
Type	Ergonomic joystick	
Translation	Driven by left joystick	
Services	Driven by right joystick for lifting and bucket	
Lifting mechanism	Vertical lifting boom with a standard self-levelling system for the bucket (only for boom rising)	

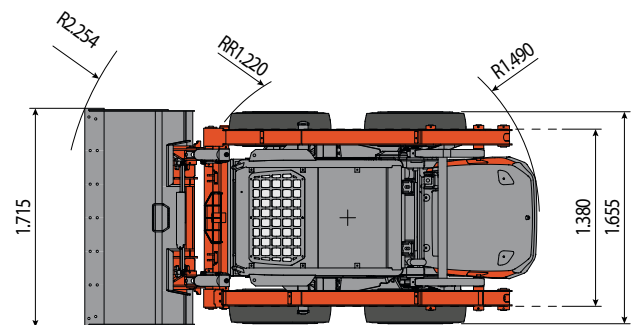
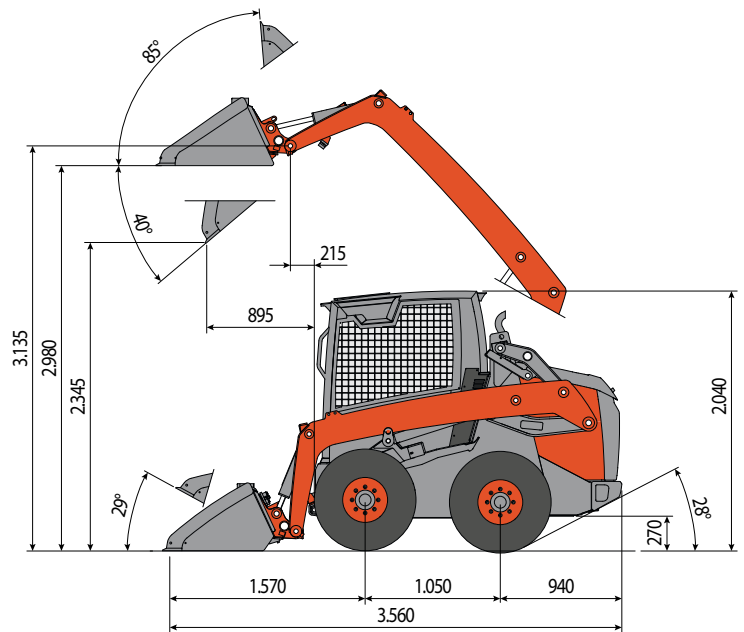

- Homologation for road traffic (only Italy).
- The ROPS (ISO 3471) – FOPS (ISO 3449) engineer standards manufactured cab or canopy.
- Front and rear lights for night-road use and working.

 **EUROCOMACH®**