



HYDRAULIC BREAKERS & ACCESSORIES

PRODUCT RANGE

Furukawa Rock Drill is synonymous with premium products that you can rely on. This brochure is intended to give you an overview of our hydraulic breakers.



Alle Produkte:
www.frd.eu



Overview

The Company profile	Page 03 - 05
Furukawa Rock Drill - FRD	04
Milestones of the company	05
The FRD Hydraulic breakers	Page 06 - 07
Introduction	06
The FX – 2 Series	Page 08 - 17
FX-2 Series	08
Areas of use and application	08
Technical drawing	10 - 11
Features and benefits	10 - 11
Differences and characteristics	12 - 14
Technical data	16 - 17
The F Series	Page 18 - 25
F Series	18
Areas of use and application	18
Technical drawing	20
Features and benefits	21
Differences and characteristics	22 - 23
Technical data	24 - 25
The FXJ Series	Page 26 - 37
FXJ Series	26 - 27
Technical drawing	28 - 29
Features and benefits	30
Areas of use and application	31
Differences and characteristics	32 - 35
Technical data	36 - 37
The Rods	Page 38 - 45
Rods	38
Differences and characteristics	39 - 41
Technical data	42 - 45
The Toolcases	Page 46 - 47
Delivery scope	46
variations of the toolcases	46 - 47

Hydraulic breaker Accessories	Page 48 - 49
Armour Plates	48
Swivel Adapter	49
The SenciLube	Page 50 - 51
SenciLube	50
Differences and characteristics senci rod grease	51



PROMPT, SAFE, ON-SITE

Our service for you

The tools from FRD represent premium equipment that our customers enjoy working with. The products have been developed to cover a wide range of applications, carrier devices and materials. A wide network of selected dealers is at your disposal to ensure the best possible support. They will provide you with reliable support for all aspects of our product lines and ensure that you will find the right machines to suit your needs. In line

with our quality standards, we are always ready to offer you our technical expertise if you have any special requests. By working closely together, we are able to establish all the prerequisites for you to always work professionally. Take advantage of our extensive knowledge and our intelligent machine range featuring premium quality. Do not hesitate to contact us if you have any questions.

WE STAND FOR THIS



HIGH
QUALITY



RELIABLE
PRODUCTS



TOP
CUSTOMER SERVICE

THE DESIRE FOR PERFECTION

FURUKAWA ROCK DRILL - FRD

Few countries in the world exemplify precision work and innovative technology as much as Japan.

The Japanese art of manufacturing with its aspiration to perfection is deeply rooted in the country's tradition and is something that has been fostered for centuries. All Furukawa Rock Drill (FRD) products reflect this philosophy. The company was established by Ichibei Furukawa, who started a copper mining venture in 1875. He repaired and serviced the imported rock drills he used in the Ashio copper mine by himself. In 1914, Mr. Furukawa designed his rock breaking equipment which met his requirements. These high-performance and extremely robust tools laid the foundation for the success of his company a few years later.

The Furukawa Group today exists of a total of 8 corporate groups, where in-depth knowledge of metal processing as well as the design and construction of first-class machines play a significant role. The hydraulic breakers, surface drilling rigs, excavation machines and hydraulic demolition equipment from FRD are now in use all over the world. These premium machines break, drill, grab and crush a wide variety of materials in various applications: in infrastructure, construction, demolition, recycling, surface and underground mining as well as natural stone quarries. FRD has branches in

Europe, the United States, Latin America, Korea and China to provide you with reliable support.

The desire for perfection continues to drive us. This is why the Innovations Lab of the Furukawa Group is continuously conducting research into technical innovations for even more powerful, durable and maintenance-friendly machines that you can count on.

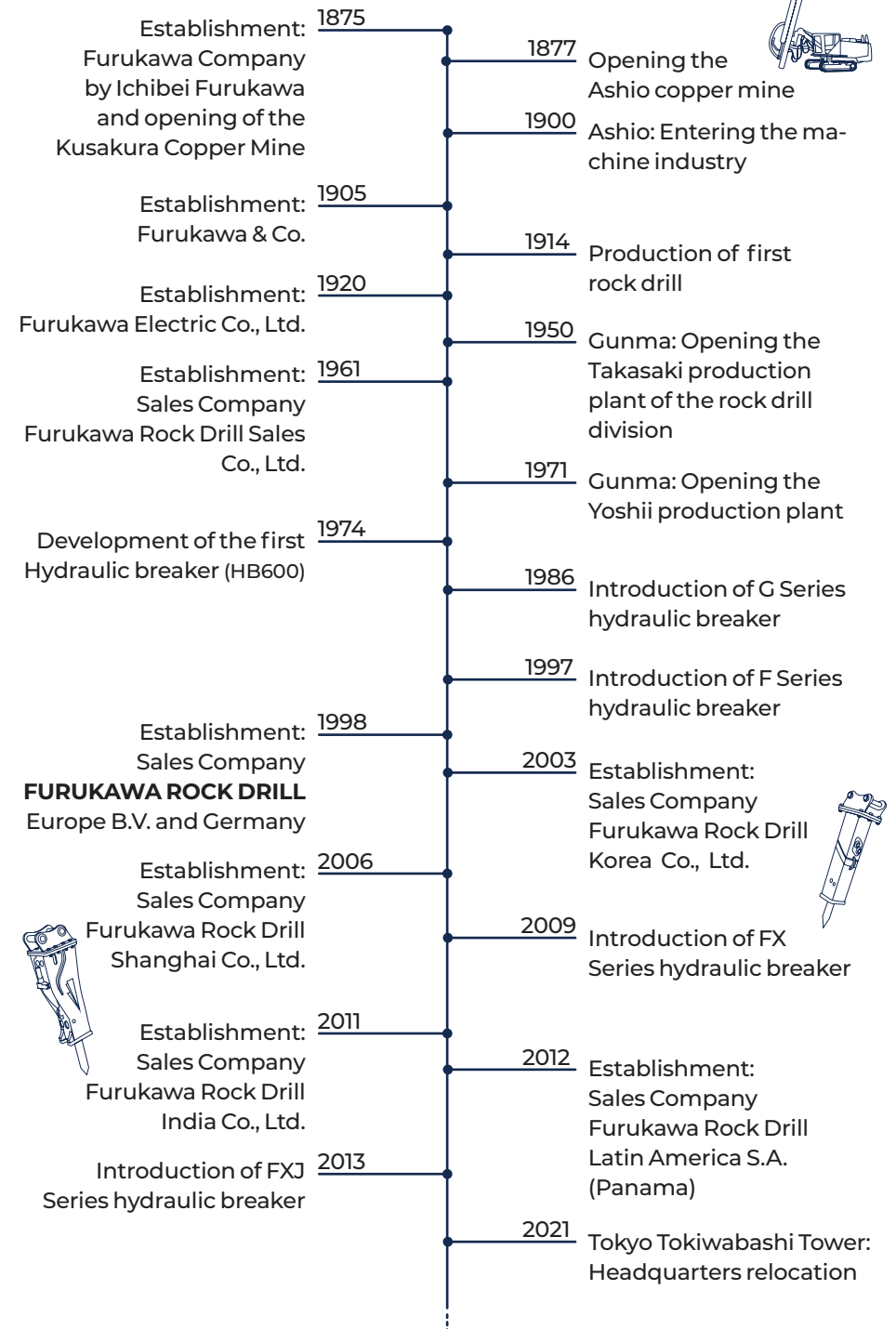

TOP-CLASS EQUIPMENT

The hydraulic breakers



The hydraulic breakers manufactured by FRD represent premium products, developed for a wide range of applications and materials.

Our products give you low-maintenance, high-performance tools that are engineered to meet your specific requirements. Our hydraulic breakers reflect over 50 years of engineering expertise, comprehensive steel know-how and extensive practical experience gained with efficient im-

compact systems for demolition work. Our three high-quality FRD Series provide hydraulic demolition breakers suitable for every carrier and every task – from professionals for professionals. For maximum productivity and pleasant work. See for yourself.

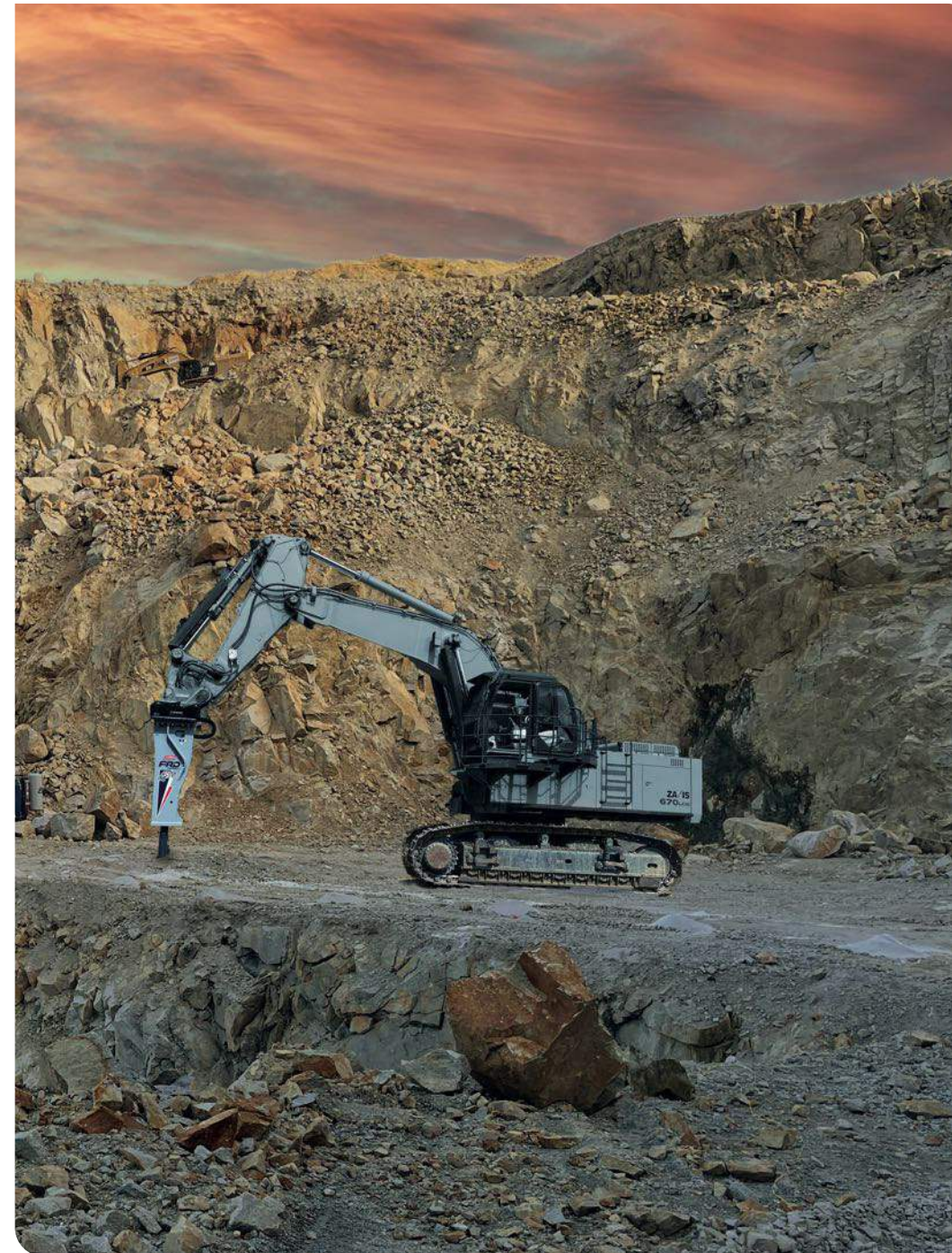

THE FX-2 SERIES

Impact that lasts

With the FX-2, we have taken our successful model and tailored it even more precisely to your needs.

The latest generation of the FRD small breaker Series for mini-excavators from 0.5-7 tonnes impresses with its low-maintenance monobloc design and first-class materials for particularly durable premium hydraulic breakers with exceptional high efficiency. The FX-2 Series features five models and three housing types for you to choose from. The three housing types FT, S and XS come with a user-friendly flange connection. This means that connection brackets can be used for all kinds of quick-change systems. The

closed housing types S and XS are also characterised by particularly low noise and vibration levels. The new design makes the S and XS housing types up to ten decibels quieter than the standard FT housing.

The state of art XS housing in combination with its patented rod design offer you the highest noise reduction level currently feasible for small hydraulic breakers. This makes the FRD hydraulic breakers even more user-friendly to work with.



Highlights of the *monobloc construction*



Low maintenance



Extremely durable



Compact design types of rods

Areas of use and application

- Road construction
- Garden & landscaping
- Trench construction
- Secondary demolition work
- Cleaning of crucibles and converters in casting plants



COMPONENT OVERVIEW

FX15 - FX35 Series

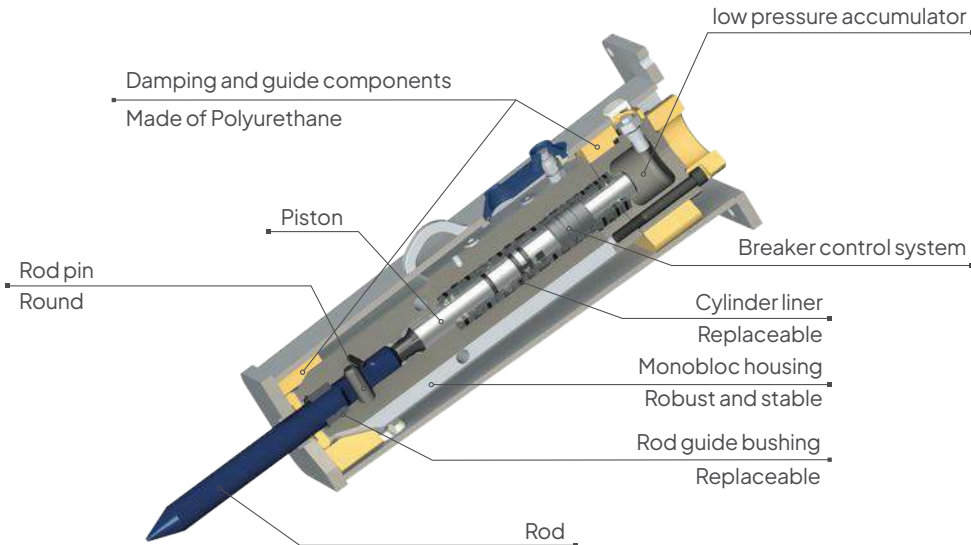

FX15 to FX35 features and benefits

- Reduced maintenance costs thanks to monobloc design with only two moving parts
- No through bolts to maintain
- No diaphragm to replace
- Replaceable rod guide bushing keeps the rod in peak performance
- Wide range of oil pick up for fast, hard-hitting performance and wide carrier options
- A variety of mounting options to suit any carrier and application
- A wide range of rods
- Includes two-year warranty with registration

COMPONENT OVERVIEW

FX45 - FX55 Series

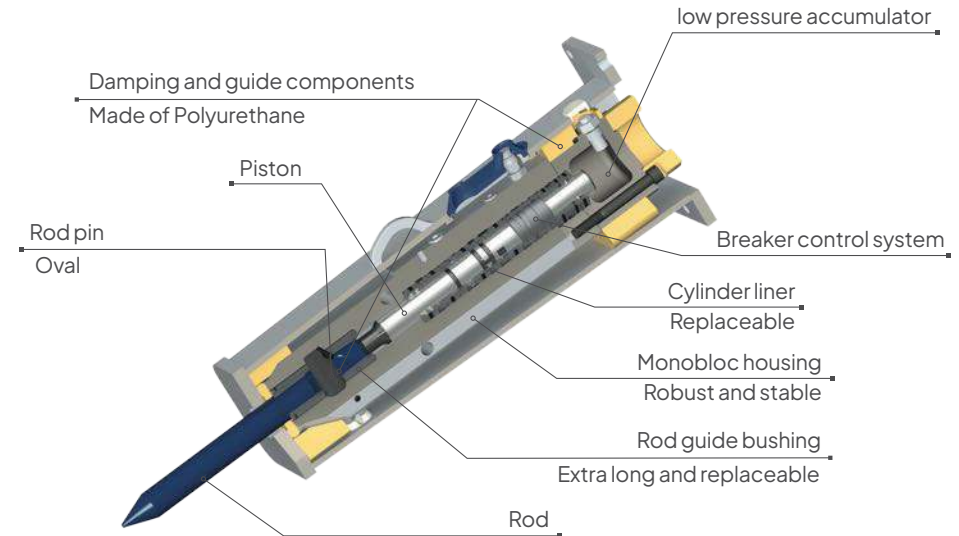

FX45 to FX55 features and benefits

- Reduced maintenance costs thanks to monobloc design with only two moving parts
- Replaceable cylinder liner
- Extra long and replaceable rod guide bushing keeps the rod in alignment for maximum service life
- Oval rod pin for increased strength and contact surface
- No diaphragm to replace
- Wide range of oil pick up for fast, hard-hitting performance and wide carrier options
- A variety of mounting options to suit any carrier and application
- A wide range of rods
- Includes two-year warranty with registration

THE FX-2 SERIES

Differences and characteristics

FX15-2

The FX15-2 is practically a feather-weight thanks to its service weight of just 69 kilograms. The small FRD hydraulic breaker for 0.5-1.5 tonnes carriers impresses with its design, high-quality construction and high impact speed. High performance guaranteed. Six different rods are available for the FX15-2. This leaves you with a wide range of applications. The FX15-2 comes with the FT housing type.



FT

FX35-2

The FX35-2 has been designed to broaden your working range, since this extremely robust hydraulic breaker is suitable for carriers of 1.5-4 tonnes. There are also six rods and the three housing types FT, X and XS available - to suit your needs. As a result, the FX35-2 is a high-performance, long-lasting premium breaker that can be used in multiple applications and locations.



FT

S

XS

FX25-2

The FX25-2 supports carriers of 1-2.5 tonnes in countless applications; It breaks masonry as well as asphalt or stones. It is extremely robust and high-performance thanks to its high-quality structure. The FX25-2 can be combined with six rods. The three housing types FT, S and XS are available for this version. When combined, all these guarantees perfect interaction for any application and location.



FT

S

XS

FX45-2

Unbeatable: The FX45-2 has been specifically designed for carriers from 2.5-5.5 tonnes. This model for mini excavators is extremely productive and reliable. It achieves significantly more per hour in comparison to all similar models on the market - thanks to a faster impact rate and a greater tool penetration. Six rods are available for the FX45-2 hydraulic breaker, as well as the three housing types: FT, S and XS.



FT

S

XS

THE FX-2 SERIES

Differences and characteristics

FX55-2

This premium hydraulic breaker is designed for carriers from 4-7 tonnes. Its innovative design requires fewer moving parts than the previous model. We were able to make the FX55-2 even lighter in combination with the particularly high-quality materials, and this without any loss of performance. Six FRD rods are available for this hydraulic breaker. It also comes in the three housing types FT, S and XS.

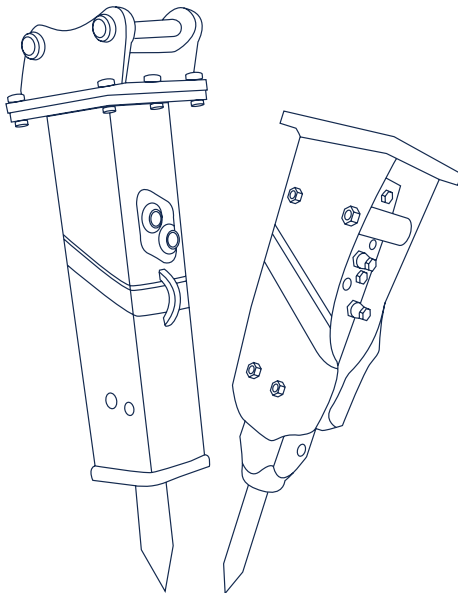

THE FX-2 SERIES
Technical data

MODEL	HOUSING TYPE	CARRIER WEIGHT CLASS 1) T	OPERATING WEIGHT 2) KG	HEIGHT WITH ROD MM	ROD DIAMETER Ø MM	ROD LENGTH MM	MAX. HYDRAULIC INPUT POWER KW	OIL FLOW L/MIN	OPERATING PRESSURE MPA	IMPACT RATE 1/MIN	NOISE LEVEL (GUARANTEED) DB(A)	HOSE INNER DIA. Ø (IN/OUT) MM
FX15-2	FT	0,5 ~ 1,5	69	816	36	234	6,5	10 ~ 28	10 ~ 14	600 ~ 1500	116	9
FX25-2	FT	1,0 ~ 2,5	101	939	45	293	8,2	18 ~ 35	10 ~ 14	600 ~ 1500	118	12
FX25-2	S	1,0 ~ 2,5	112	961	45	293	8,2	18 ~ 35	10 ~ 14	600 ~ 1500	112	12
	XS			1051							110	
FX35-2	FT	1,5 ~ 4,0	146	1060	52	322	13,9	24 ~ 52	12 ~ 16	600 ~ 1300	124	12
FX35-2	S	1,5 ~ 4,0	157	1062	52	322	13,9	24 ~ 52	12 ~ 16	600 ~ 1300	119	12
	XS			1116							117	
FX45-2	FT	2,5 ~ 5,5	187	1167	60	355	16,0	30 ~ 60	12 ~ 16	600 ~ 1100	126	12
FX45-2	S	2,5 ~ 5,5	208	1173	60	355	16,0	30 ~ 60	12 ~ 16	600 ~ 1100	120	12
	XS			1227							117	
FX55-2	FT	4,0 ~ 7,0	245	1264	68	378	22,7	40 ~ 84	12 ~ 16	500 ~ 1100	126	12
FX55-2	S	4,0 ~ 7,0	280	1276	68	378	22,7	40 ~ 84	12 ~ 16	500 ~ 1100	119	12
	XS			1330							116	

Subject to technical changes without prior notice by the manufacturer.

1) Weights apply only to standard carrier units. Any deviations must be agreed with FRD or the manufacturer of the carrier unit before attachment.

2) Weight including insertion tool, hose set, medium size attachment plate. (According to CE guidelines)

THE F SERIES

Simply unsurpassed robustness

The F Series has been specially developed for midi-excavators and backhoe loaders.

The hydraulic breakers of the F Series work flawlessly in combination with carriers of 5-12 tonnes. It remains one of our most successful flagship products to this day. There is a good reason for that, because the F Series

is extremely robust, efficient and reliable. The high quality product is available in four versions to suit a variety of carriers and application: F6BHL, F6FT, F6LN and F9LN.



Highlights of the F Series



Extremely robust and powerful



High durability



Excellent construction

Areas of use and application

- Road construction
- Garden & landscaping
- Trench construction
- Secondary demolition work
- Cleaning of crucibles and converters in casting plants



COMPONENT OVERVIEW

F6 and F9 Series

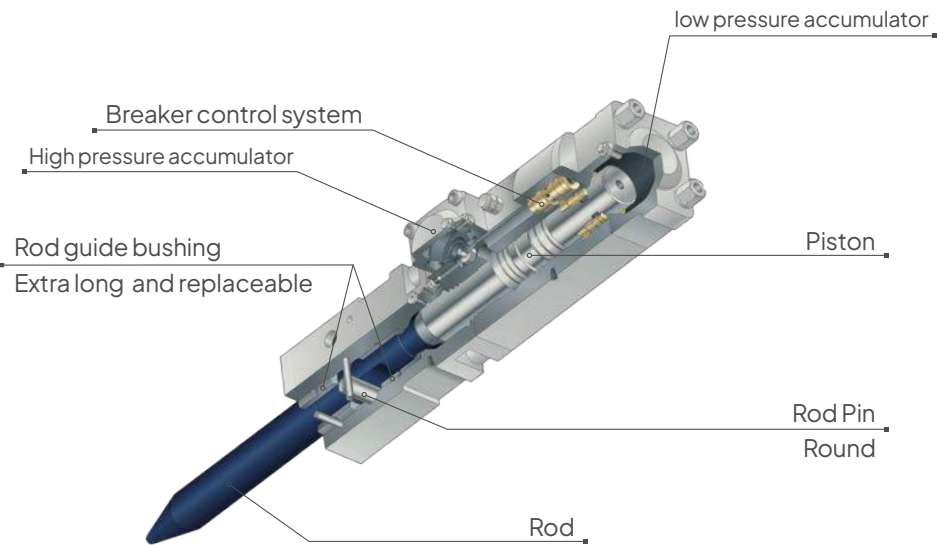

F Series features and benefits

- Extremely robust and durable
- Large piston for maximum impact energy
- Replaceable rod guide bushings keeps the rod in proper alignment for maximum durability
- Two rod pins for increased steel contact and double service life
- Wide range of oil pick up for fast, hard-hitting performance and wide carrier options
- A variety of mounting options to suit any carrier and application
- A wide range of rods
- Includes two-year warranty with registration



THE F SERIES

Differences and characteristics

F6

The F6BHL is equipped with a special housing for backhoe loaders. It is perfectly suited for carriers from 3.5-10 tonnes. The premium hydraulic breaker can be optimally placed in the transport position of the backhoe loader with this housing. This ensures that it can be used on the road. The F6BHL boasts exceptionally high impact power for its performance group and also has a very robust design. Five rods are available for the model.



BHL

F6

Carriers from 5-9 tonnes are suitable for the F6LN. It has a housing that is low in noise and vibration. This makes this version a convincing choice thanks to its high impact power at low noise levels. The F6LN is therefore perfect in all situations where minimising noise is essential. The LN housing ensures that the hydraulic breaker of the F Series operates up to 4 dB (A) quieter than the standard FT housing. There are five rods for the F6LN.



LN

F6

The F6FT premium hydraulic breaker is perfect for carriers from 5-9 tonnes. It offers particularly high performance and breaks natural stone, asphalt and concrete with ease. The hydraulic breaker comes with the housing type FT, the flange connection. This design, being the classic connection, also represents the most favourable solution for attaching various quick-change systems to a hydraulic breaker flexibly and quickly. Five rods are available for the F6FT.



FT

F9

This F Series model is designed to work with 6-12 tonnes carriers. The F9LN comes with the noise-reducing LN housing, meaning: The hydraulic breaker works exceptionally and quietly. It is therefore suitable for use wherever the noise level has to be kept low while at the same time ensuring high performance. Five rods are available for the F9LN.



LN





THE F SERIES

Technical data

MODEL	HOUSING TYPE	CARRIER WEIGHT CLASS ¹⁾	OPERATING WEIGHT ²⁾	HEIGHT WITH ROD	ROD DIAMETER Ø	ROD LENGTH	MAX. HYDRAULIC INPUT POWER	OIL FLOW	OPERATING PRESSURE	IMPACT RATE	NOISE LEVEL (GUARANTEED)	HOSE INNER DIA Ø (IN/OUT)
		T	KG	MM	MM	MM	KW	L/MIN	MPA	1/MIN	DB(A)	MM
F6	BHL	5 ~ 10	365	1450	75	450	21,0	50 ~ 90	10 ~ 14	650 ~ 1050	129	12
F6	FT	5 ~ 10	365	1450	75	450	21,0	50 ~ 90	10 ~ 14	650 ~ 1050	129	12
F6	LN	5 ~ 10	350	1400	75	450	21,0	50 ~ 90	10 ~ 14	650 ~ 1050	125	12
F9	LN	7 ~ 12	535	1595	90	500	27,5	65 ~ 110	12 ~ 17	550 ~ 900	125	19

Subject to technical changes without prior notice by the manufacturer.

1) Weights apply only to standard carrier unit. Any deviations must be agreed with FRD or the manufacturer of the carrier unit before attachment.

2) Weight including insertion tool, hose set, medium size attachment plate. (According to CE guidelines)



THE FXJ SERIES

Uniquely hard-hitting and progressive

We have succeeded in systematically advancing a new generation of premium hydraulic breakers with the FXJ Series.

We have designed a low-maintenance impact mechanism in slim design for the FXJ Series in order to extend the service life of the high-performance tool even further: The monobloc design does away with a separate cylinder, front head and through bolts. The square-edged design also makes the FXJ Series even more sturdy, lightweight and produc-

tive. Through bolts have been completely omitted up to the FXJ475. The new valve design reduces hydraulic oil temperature and boosts the performance, and it makes the breaker compatible with wider range of oil intake. This has allowed us to engineer a breaker Series that delivers higher impact and speed. The incredibly efficient premium hydraulic breakers

of the FXJ Series are unique on the market with these design features. The FXJ Series exists of numerous medium (FXJ125-275) and large (FXJ375-1070) sized hydraulic breakers. Many different types of rods are available. Our heavyweights, FXJ770 and FXJ1070 are built according to our proven design with implementation of the new, performance-enhancing fea-

tures, such as; the vibration-damping heavy duty through bolts, replaceable cylinder liner, improved valve design and greater back head gas pressure.

Technical data
on page 36/37

The FXJ Series at a glance



COMPONENT OVERVIEW FXJ125 – FXJ475 Series

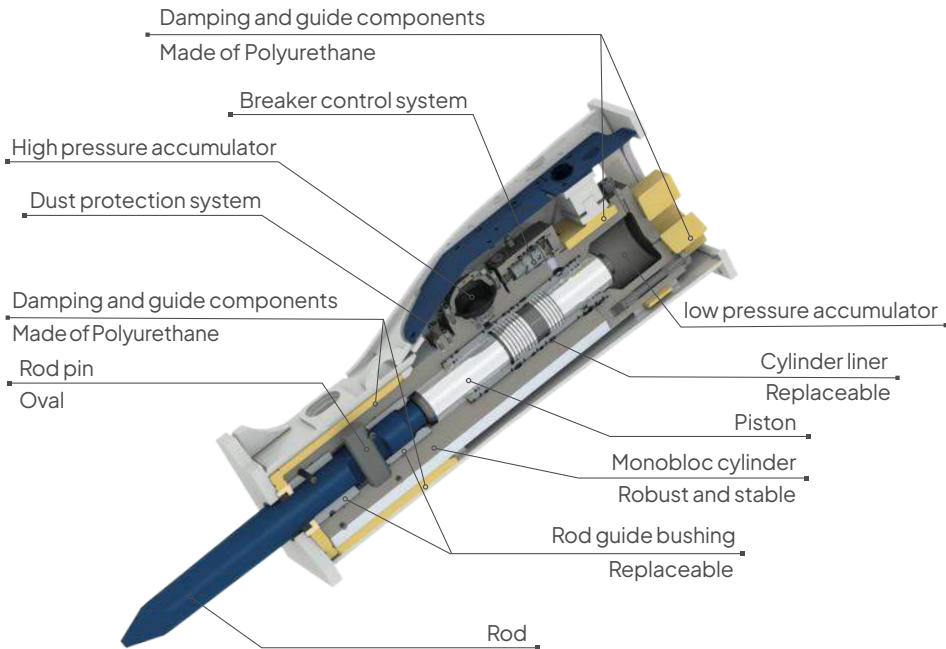

FXJ125 to FXJ475 features and benefits

- Reduced maintenance costs due to monobloc design
- Square monobloc design promises highest strength
- No separate cylinder and front cylinder, and through bolts thanks to Monobloc design

COMPONENT OVERVIEW FXJ770 – FXJ1070 Series

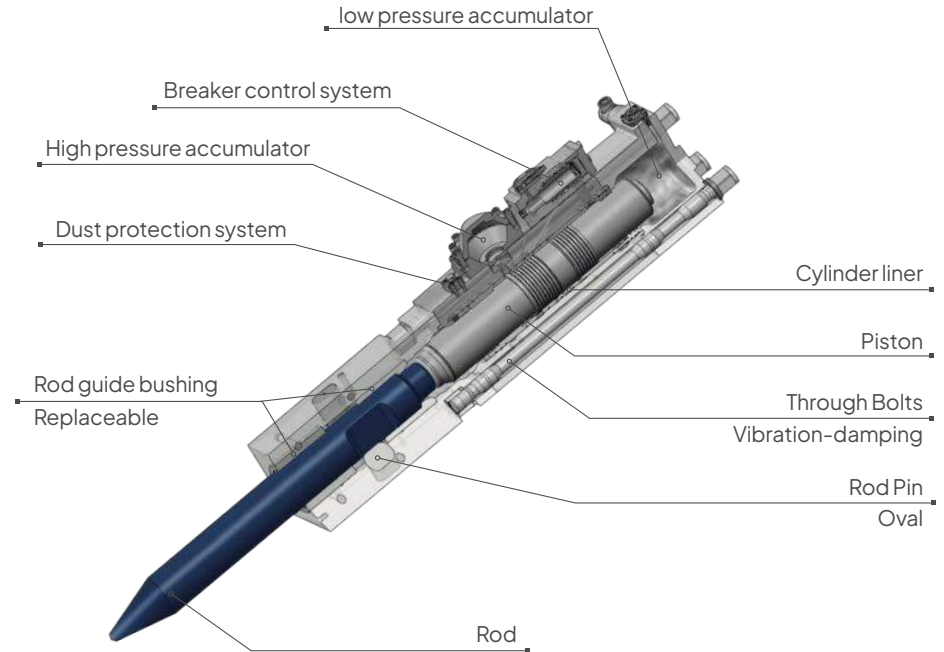

FXJ770 to FXJ1070 features and benefits

- Square front cylinder and cylinder construction for highest strength
- The newly designed piston increases surface contact with the rod
- Vibration-damping through bolts with larger diameter for longer service life
- Increased back head pressure for more impact power

Info: **Without** through bolts construction from FXJ125 – FXJ475 | **With** through bolts construction from FXJ770 and FXJ1070



Highlights of the FXJ Series



Low
operating costs



High
durability



Damping system for
low noise

FXJ Series features and benefits

- Replaceable cylinder liner with concentric ports keeps piston aligned for maximum impact and reduces overall maintenance costs
- Increased performance due to improved valve design reduces the temperature of the hydraulic fluid
- An active check valve ventilates the impact area during the upward movement of the piston, minimizing the ingress of abrasive dust and expelling dust-contaminated lubricant from the rod guide system (excluding FXJ 125)
- Increased hydraulic flow range for use on a larger number of carriers
- Minimizes internal contamination through three-point dust prevention
- Increased contact surface between piston and rod thanks to the state of art impact piston design
- The increased surface area of the rod guide bushings keeps the rod optimally aligned for greater impact force
- SV housing (system for sound and vibration Reduction), the system separates the percussion unit and the housing by damping and guiding elements made of Polyurethane. The sealing of the hydraulic hammer openings reduces the noise and vibration levels
- Improved lubrication for wear components
- The improved rod pin design results in better distribution of load. This in combination with reliable locking system for quick rod change and increased durability

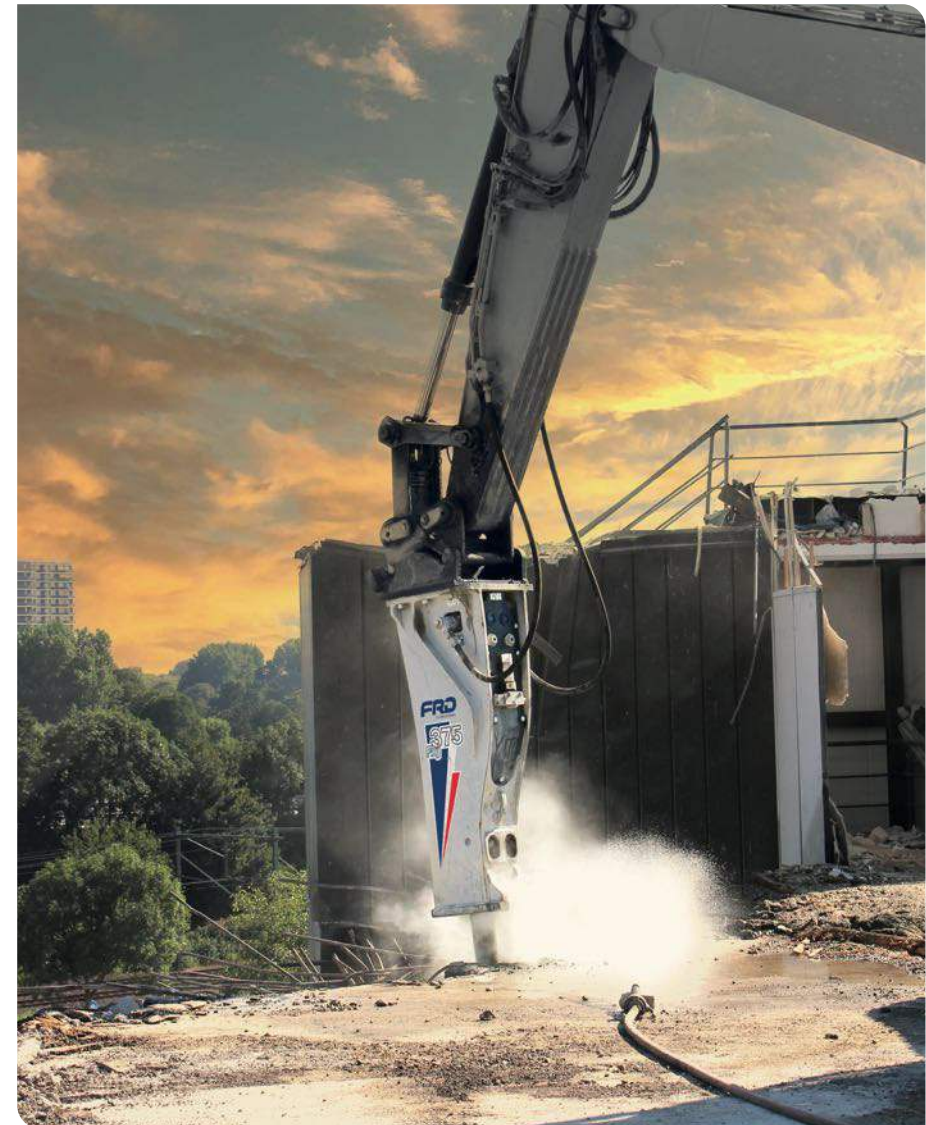

Areas of application

- Demolition work
- Foundation work
- Trench construction
- Direct extraction from the quarry
- Bouldering work
- Excavation work
- Cleaning & dismantling of brick linings



FXJ125 UP TO 275 SERIES

Differences and characteristics

FXJ125-2

Extremely efficient and versatile: The FXJ125-2 mid-range breaker has been specially developed for midi, mobile excavators and boom systems. Carriers weighing 9 - 16 tonnes are suitable for the premium tool. The monobloc design of the hydraulic breaker ensures maximum efficiency with a long service life. The elimination of through bolts has also been shown to significantly reduce downtimes. The result: simply powerful.



SV

FXJ225

Premium crushing force: The FXJ225 hydraulic breaker is optimised for carriers weighing 16 - 26 tonnes. The extremely robust FRD impact mechanism with monobloc design also supports you during challenging work - for example in demolition projects or as a production machine in the quarry and reliably at all times. The advanced and well thought-out design of the premium tool also ensures a particularly long service life.



SV

FXJ175

The FXJ175 mid-range breaker for carriers weighing 12 - 21 tonnes reflects its design and is an extremely powerful hydraulic breaker with a long service life. The premium working tool is fitted with integrated piston stroke adjustment as standard, optimising overall performance. The FXJ175 has been prepared for automatic lubrication systems at the factory and can be connected directly to our SenciLube lubrication system.



SV

FXJ275-2

The FXJ275-2 is a particularly high-performance and reliable all-rounder from the premium segment: It has been designed for a wide range of carriers weighing between 21-30 tonnes. The low-maintenance FRD hydraulic breaker comes with all the award-winning features of the FXJ Series and delivers a unique, high-performance tool thanks to its monobloc design, dust protection system, new valve design for lowering hydraulic oil temperatures and redesigned percussion piston.



SV

FXJ375 UP TO 1070 SERIES

Differences and characteristics

FXJ375-2

The FXJ375-2 model has been designed for excavators in the 25-42 tonnes class. The very robust hydraulic breaker is suitable for a wide range of applications. The advanced monobloc design and new structural concept have allowed us to significantly increase the performance of the model. Fitted with a piston stroke adjustment mechanism, the FXJ375's piston stroke length regulates the power and speed characteristics thus optimising overall performance.



SV

FXJ770-2

It is perfectly suited for heavy weights from 44-75 tonnes. The extra-large breaker features a replaceable cylinder liner, higher back head gas pressure, increased surface area of the rod guide bushings and newly designed vibration-dampened large-diameter Heavy Duty through bolts. It is intended for blasting-free primary rock excavation and secondary breaking on construction sites and in quarries, in surface and underground mining, as well as for demolishing massive reinforced concrete structures.



SV

FXJ475-2

Excavators in the 33-55 tonnes class make the perfect carriers for this FRD premium hydraulic breaker. The monobloc design, back head gas pressure and new percussion piston ensure that you can rely on a high-performance robust and low-noise tool. It breaks, for example, blue granite in Scandinavia as well as oversized boulders in Spain. The FXJ475-2 is prepared for automatic lubrication systems at the factory.



SV

FXJ1070-2

The FXJ1070-2 is the biggest breaker in the Series. It is suited for carriers from 65-110 tonnes. The premium model is ideally tailored for massive demolition work, direct quarrying or bouldering operations in quarries, ground levelling or channel deepening. The FXJ1070-2 is exceedingly robust and high-performance. This is achieved thanks to the higher back head gas pressure, newly designed percussion piston shape and the vibration-dampened Heavy Duty through bolts with a larger diameter.



SV



THE FXJ SERIES

Technical data

MODEL	HOUSING TYPE	CARRIER WEIGHT CLASS 1)	OPERATING WEIGHT 2)	HEIGHT WITH ROD	ROD DIAMETER \varnothing	EFFECTIVE	LENGTH ROD	MAX. HYDRAULIC INPUT POWER	OIL FLOW	OPERATING PRESSURE	IMPACT RATE	NOISE LEVEL (GUARANTEED)	HOSE INNER DIA \varnothing (HD/ND)
MEDIUM HYDRAULIC BREAKERS		T	KG	MM	MM	MM	KW	L/MIN	MPA	1/MIN	DB(A)	MM	
FXJ125-2	SV	9 ~ 16	800	2005	110	640	36,0	70 ~ 120	16 ~ 18	400 ~ 1000	129	19	
FXJ175	SV	12 ~ 21	1000	2043	120	620	48,0	100 ~ 160	16 ~ 18	450 ~ 900	120	19	
FXJ225	SV	16 ~ 25	1600	2411	135	650	57,0	125 ~ 190	16 ~ 18	350 ~ 850	121	25	
FXJ275-2	SV	21 ~ 30	1800	2468	140	680	66,0	145 ~ 220	16 ~ 18	350 ~ 620	127	25	
LARGE HYDRAULIC BREAKERS													
FXJ375-2	SV	25 ~ 42	2600	2715	155	715	78,0	170 ~ 260	16 ~ 18	300 ~ 550	123	25	
FXJ475-2	SV	33 ~ 55	3200	2892	170	720	90,0	200 ~ 300	16 ~ 18	250 ~ 450	124	32	
FXJ770-2	SV	44 ~ 75	4800	3390	190	860	102,0	250 ~ 340	16 ~ 18	250 ~ 420	124	32	
FXJ1070-2	SV	65 ~ 110	6600	3800	210	980	126,0	280 ~ 420	16 ~ 18	200 ~ 375	128	32	

Subject to technical changes without prior notice by the manufacturer.

1) Weights apply only to Std. carrier units. Any deviations must be agreed with FRD or the manufacturer of the carrier unit before attachment.

2) Weight including insertion tool, hose set, medium size attachment plate. (According to CE guidelines)

PERFECT IN INTERACTION

Rods for FRD hydraulic breakers

FRD rods reflect extensive expertise involving steel, steel processing and design.

This allows us to offer our customers reliable support in the most versatile areas of application. Whether in road construction, during demolition work, trench excavation, quarrying work, tunnel advancement or mining. Several rod types in premium quality are available for the FRD hydraulic breaker Series.

Highlights of the FRD Rods



High performance



Premium quality



Endurance

3D - Overview of all Rods

FX-2 and F Series



FXJ Series



THE RODS

Features

Cone Rod

The cone point is perfectly suited for general work thanks to its excellent penetration capability and good wedging action in all directions. No torsional effect is present in the cone point. Its point facilitates optimal positioning and is particularly effective with small-diameter rods, such as the FX series.

This rod type is suitable for very different areas of application: It breaks concrete, sedimentary rock as well as limestone, sandstone, greywacke and chalky sediment.

3D - Representation



Sketches - illustration



Pressure distribution view



Moil Rod

The moil point rod represents a further development of the cone point, it features a good wedging effect in four directions and the torsional effect is low. Its pyramid shape ensures optimal positioning, it is most suitable for large diameter rods such as used with the F and FXJ Series.

This rod type is suitable for different areas of application: It breaks concrete, sedimentary rock as well as limestone, sandstone, greywacke and chalky sediment.

3D - Representation



Sketches - illustration



Pressure distribution view

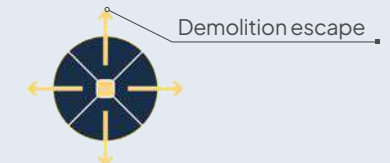

Wedge Rod

The wedge rod delivers outstanding wedging action in two directions. The force transmitted by the breaker is distributed over a larger area in line with its wider, flat cutting edge. It breaks reinforced concrete extremely well and is ideal in the primary fracture range for crushing rock with severe fracturing. Other areas of application include excavating trenches and pits as well as operating on slopes with ground gradients.

3D - Representation



Sketches - illustration



Pressure distribution view



Wide chisels & asphalt spades

Wide chisels and asphalt spades feature a straight blade edge and possess significantly wider cutting edges than a wedge rod. Meaning: The force distribution and area output is greater. They vary in design and are therefore suitable for different areas of application. As the name already implies, the asphalt spade is optimised for asphalt work. The asphalt spade finds its place of service wherever asphalt or soft material needs to be cut. The wide chisel is designed for breaking up asphalt surfaces, but it can also be used to crack open pouring ladles and suitable for breaking (reinforced) concrete.

3D - Representation



Sketches - illustration



Pressure distribution view



Flat Rod

The flat rod optimally transfers the full impact force of the breakers to the material it is intended to crush. This does not penetrate the material. This rod type is the tool of choice when it comes to secondary demolition in quarries and bouldering, for example, and is suitable for concrete demolition or slag bears. It is perfect for separating concrete and reinforcements in the recycling sector. It is very good at breaking oversized stones in secondary crushing operations. When it comes to primary fracturing work, its areas of application include volcanic rock, diabase, gabbro, granite with slight cracking.

3D - Representation



Sketches - illustration



Pressure distribution view

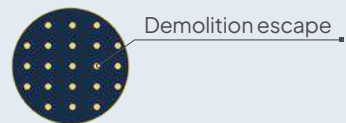

Core Rod

The core rod features a hard steel core made of tungsten carbide, which ensures that the tip of the rod always remains sharp. It has a sound wedging effect in four directions and the torsional effect is low. Its pyramid shape facilitates optimal positioning. The core rod is used for breaking off metal ores and quartzite, although it is also suitable for other highly abrasive materials.

3D - Representation



Sketches - illustration



Pressure distribution view

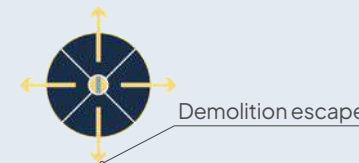

THE FRD RODS FOR THE FX AND F SERIES

Technical data

FX15-2FT & S	LENGTH	USE LENGTH	WEIGHT
ROD (ø 36 MM)	MM	MM	KG
CONE	370	234	2,8
MOIL	-	-	-
WEDGE	370	234	2,8
FLAT	370	234	2,8
WIDE	440	115	3,7
ASPHALT SPADES	440	125	3,7
CORE	-	-	-

FX25-2FT & S	LENGTH	USE LENGTH	WEIGHT
ROD (ø 45 MM)	MM	MM	KG
CONE	460	293	5
MOIL	-	-	-
WEDGE	440	293	5
FLAT	460	293	5
WIDE	440	120	5
ASPHALT SPADES	450	100	5
CORE	460	293	5

FX45-2XS	LENGTH	USE LENGTH	WEIGHT
ROD (ø 60 MM)	MM	MM	KG
CONE	615	355	12,1
MOIL	-	-	-
WEDGE	615	355	12,1
FLAT	615	355	12,1
WIDE	UPON REQUEST		
ASPHALT SPADES	UPON REQUEST		
CORE	560	355	11

FX55-2FT & S	LENGTH	USE LENGTH	WEIGHT
ROD (ø 68 MM)	MM	MM	KG
CONE	600	378	15
MOIL	-	-	-
WEDGE	600	378	15
FLAT	600	378	15
WIDE	560	150	16,5
ASPHALT SPADES	590	150	16,5
CORE	600	378	15

FX25-2XS	LENGTH	USE LENGTH	WEIGHT
ROD (ø 45 MM)	MM	MM	KG
CONE	515	293	5,8
MOIL	-	-	-
WEDGE	515	293	5,8
FLAT	515	293	5,8
WIDE	UPON REQUEST		
ASPHALT SPADES	UPON REQUEST		
CORE	460	293	5

FX35-2FT & S	LENGTH	USE LENGTH	WEIGHT
ROD (ø 52 MM)	MM	MM	KG
CONE	510	322	8
MOIL	-	-	-
WEDGE	510	322	8
FLAT	510	322	8
WIDE	500	140	8,5
ASPHALT SPADES	510	115	8,5
CORE	510	322	8

FX55-2XS	LENGTH	USE LENGTH	WEIGHT
ROD (ø 68 MM)	MM	MM	KG
CONE	655	378	16,4
MOIL	-	-	-
WEDGE	655	378	16,4
FLAT	655	378	16,4
WIDE	UPON REQUEST		
ASPHALT SPADES	UPON REQUEST		
CORE	600	378	15

FX35-2XS	LENGTH	USE LENGTH	WEIGHT
ROD (ø 52 MM)	MM	MM	KG
CONE	565	322	8,5
MOIL	-	-	-
WEDGE	565	322	8,5
FLAT	565	322	8,5
WIDE	UPON REQUEST		
ASPHALT SPADES	UPON REQUEST		
CORE	510	322	8

FX45-2FT & S	LENGTH	USE LENGTH	WEIGHT
ROD (ø 60 MM)	MM	MM	KG
CONE	560	355	11
MOIL	-	-	-
WEDGE	560	355	11
FLAT	560	355	11
WIDE	500	150	9
ASPHALT SPADES	520	130	9
CORE	560	355	11

F6	LENGTH	USE LENGTH	WEIGHT
ROD (ø 75 MM)	MM	MM	KG
CONE	-	-	-
MOIL	730	450	21,5
WEDGE	730	450	21,5
FLAT	730	450	21,5
WIDE	670	150	20
ASPHALT SPADES	700	150	20
CORE	730	450	21,5

F9	LENGTH	USE LENGTH	WEIGHT
ROD (ø 90 MM)	MM	MM	KG
CONE	-	-	-
MOIL	840	500	35,5
WEDGE	840	500	35,5
FLAT	840	500	35,5
WIDE	740	180	33
ASPHALT SPADES	780	200	33
CORE	840	500	35,5

THE FRD RODS FOR THE FXJ SERIES

Technical data

FXJ125	LENGTH	USE LENGTH	WEIGHT
ROD (∅ 110 MM)	MM	MM	KG
CONE	-	-	-
MOIL	1070	680	69
WEDGE	1070	680	69
FLAT	1070	680	69
WIDE	-	-	-
ASPHALT SPADES	-	-	-
CORE	1070	680	69

FXJ175	LENGTH	USE LENGTH	WEIGHT
ROD (∅ 120 MM)	MM	MM	KG
CONE	-	-	-
MOIL	1110	695	76
WEDGE	1110	695	76
FLAT	1110	695	76
WIDE	-	-	-
ASPHALT SPADES	-	-	-
CORE	1110	695	76

FXJ770	LENGTH	USE LENGTH	WEIGHT
ROD (∅ 190 MM)	MM	MM	KG
CONE	-	-	-
MOIL	1735	860	315
WEDGE	1735	860	315
FLAT	1735	860	315
WIDE	-	-	-
ASPHALT SPADES	-	-	-
CORE	1735	860	315

FXJ1070	LENGTH	USE LENGTH	WEIGHT
ROD (∅ 210 MM)	MM	MM	KG
CONE	-	-	-
MOIL	1940	980	434
WEDGE	1940	980	434
FLAT	1940	980	434
WIDE	-	-	-
ASPHALT SPADES	-	-	-
CORE	-	-	-

FXJ225	LENGTH	USE LENGTH	WEIGHT
ROD (∅ 135 MM)	MM	MM	KG
CONE	-	-	-
MOIL	1250	737	120
WEDGE	1250	737	120
FLAT	1250	737	120
WIDE	-	-	-
ASPHALT SPADES	-	-	-
CORE	1250	737	120

FXJ275	LENGTH	USE LENGTH	WEIGHT
ROD (∅ 140 MM)	MM	MM	KG
CONE	-	-	-
MOIL	1310	770	135
WEDGE	1310	770	135
FLAT	1310	770	135
WIDE	-	-	-
ASPHALT SPADES	-	-	-
CORE	1310	770	135

FXJ375	LENGTH	USE LENGTH	WEIGHT
ROD (∅ 155 MM)	MM	MM	KG
CONE	-	-	-
MOIL	1405	810	172
WEDGE	1405	810	172
FLAT	1405	810	172
WIDE	-	-	-
ASPHALT SPADES	-	-	-
CORE	1405	810	172

FXJ475	LENGTH	USE LENGTH	WEIGHT
ROD (∅ 170 MM)	MM	MM	KG
CONE	-	-	-
MOIL	1510	830	221
WEDGE	1510	830	221
FLAT	1510	830	221
WIDE	-	-	-
ASPHALT SPADES	-	-	-
CORE	1510	830	221





DELIVERY SCOPE

The Tool box/bag

Always well equipped, thanks to the FRD Tool box/bag
Special tools for quick daily maintenance!

All hydraulic breakers are supplied with a tool bag or tool box. For the FX-2 Series, one tool bag is included in the scope of delivery. For the F and FXJ Series. Tool boxes are provided. They contain the most important special tools, e.g. to enable quick replacement of the rod.

FXJ Series Toolbox



Soft toolcase for the FX Series



Manual grease gun



F Series Toolbox



Sencio White



The Armour Plates

The FRD armor plate is the optimal additional protection against wear. In trenches, during canal work or when working in quarries, the Hardox armor plate provides maximum protection

for your hydraulic breaker. Subsequent upgrading is possible by simply welding it to the hydraulic breaker housing.

Highlights of the Armour Plates

1

Robust wear protection

2

Extremely durable

3

Direct mounting

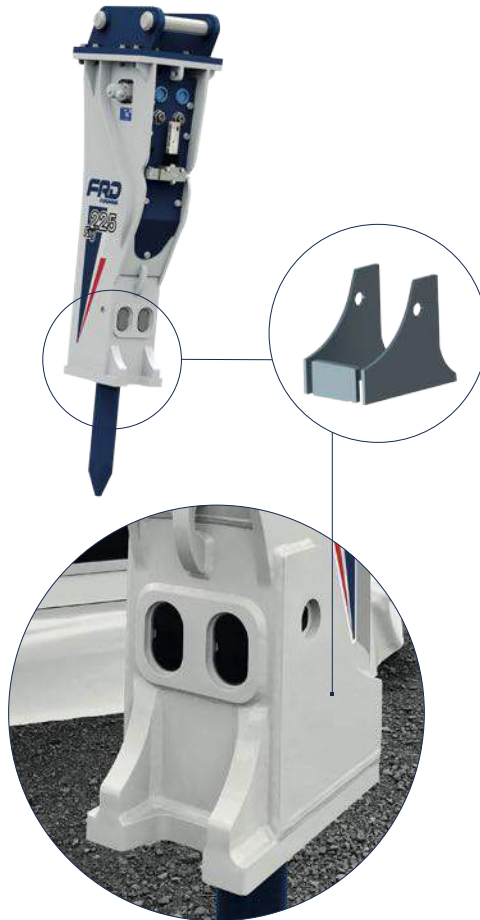

The Swivel Adapter

No more annoying incidents! Thanks to the FRD's swivel adapter. This prevents twisting or distortion of the hydraulic hoses and facilitates optimum connection.

Rapid benefits thanks to uncomplicated assembly on the breaker body. The wearing parts, such as seals, can be replaced without any problems.

Highlights of the Swivel Adapter

1

Reduces work Downtime

2

Extremely durable

3

Simple retrofit



EFFICIENT, DEMAND-ORIENTED, UNCOMPLICATED

Our lubrication system: SenciLube

The FRD SenciLube lubrication system ensures optimum lubrication of the rod guide bushings at all times and completely automatically. The uncomplicated system is mounted directly on the breaker housing. It facilitates continuously adjustable lubrication of

the tool area and consequently ensures optimum lubricant supply. The filling level of the cartridges is also easy to monitor from the excavator cab thanks to its transparent cartridges. Equally uncomplicated: Changing the cartridge.

Highlights of the SenciLube

1

Optimal lubricant supply

2

Reduced maintenance

3

Direct hammer housing assembly



GREASE

Features

Sencio Blue

Sencio Blue rod grease has been specially developed to provide optimum lubrication for the wear bushings of hydraulic breakers, helping to prevent both wear and tool breakage. The Sencio Blue tool paste from FRD is produced from lithium complex soap greases based on mineral oil. It contains a solid lubricant combination consisting of copper/graphite and molybdenum disulphide (MoS₂). This grease composition ensures a reliable separating effect and wear reduction at high surface pressures and temperatures up to 1100 °C. (P/N FGC-06713-1)



Sencio White

The **BIO Sencio White rod grease** has been approved by the European Commission for use in ecologically sensitive applications for the construction and mining industries. The special formula is made up of selected synthetic esters which, after lithium saponification, produce an extremely robust lubricating grease which is also rapidly biodegradable. Adding selected white solid lubricants resulted in a high VKA value and high pressure absorption.

(P/N FGC-06625)



EU ECO LABEL DE / 027 / 089



Authorized distributor:



01/2025-EN BREAKER | FRD ©

FRD - Furukawa Rock Drill Europe B.V. ©
Proostwetering 29 | 3543 AB Utrecht | The Netherlands
T +31 (0) 30 2412277 | E info@frd.eu | www.frd.eu