



	375B	385B
Engine	Yanmar 4TNV98C-PLYS	Yanmar 4TNV98CT-NLYS
Gross Power	49.9 kW (67 hp / 68 ps)	53.7 kW (72 hp / 73 ps)
Net Power	47.5 kW (64 hp / 65 ps)	51.1 kW (68.5 hp / 69.5 ps)
Operating Weight	3,100 kg (6,820 lb)	3,750 kg (8,267 lb)
Bucket Capacity	0.45 m ³ (0.59 yd ³)	0.5 m ³ (0.65 yd ³)

375B/385B SKID STEER LOADER

MAXIMUM RETURN ON YOUR INVESTMENT





DEPENDABLE POWER

Unmatched performance driven by Yanmar engine meets strict EU Stage V emissions standards - maximizing torque output and delivering more power at lower engine speeds. ECU improves fuel efficiency.

SPACIOUS CAB

Oversized cab is designed for safety and comfort with FOPS and ROPS.

VERSATILITY

Variable attachments can be chosen for different needs. Increased flexibility to handle more jobs with just one machine.

SELF-LEVELING VALVE

The self-leveling valve maintains an even level and keeps the highly stable design more balanced, which prevents bucket spillage and improves working efficiency.

FOUR WHEEL DRIVE

Four wheel hydraulic drive provides excellent traction, with durable driving chains.

EASY FOR SERVICE

80 degree back-tilting cab and a large rear compartment door provide safe and simple access to all service and maintenance areas.

AFTER SALES SERVICE

As a customer of LiuGong you can feel confident that our dealers and regional offices will be there to support you with training, service and maintenance needed throughout the life of your machine.

DESIGNED TO GET MORE DONE

POWERFUL PERFORMANCE

The 375B/385B comes equipped with a fuel efficient Yanmar EU Stage V engine that produces gross power of 49.9 kW (67 hp / 68 ps) - 53.7 kW (72 hp / 73 ps) at 2,400 rpm with high peak torque.

The engine is connected to a drive piston pump allowing the power transfer to the hydraulic system directly. With ECU, you can get better fuel economy.

OPTIMIZED HYDRAULICS

Two hydraulic systems: a closed circuit for driving and an open circuit for working. The driving circuit includes a highly efficient piston pump and a motor. The working circuit adopts pilot control; system flow reaches 18.3-31.8 gal/min (69-120 L/min).





ALWAYS RELIABLE

We are committed to reducing your total cost of ownership and increasing your profits.

EXCELLENT STABILITY FRAME

Mono-block frame ensures excellent stability and increased strength. Trapezoid box frame of boom is designed for high power and good stability and handles shocks and torsion well. It is also designed for high-frequency rock breaking.

SELF-LEVELING LINKAGE

The self-leveling valve maintains an even level and keeps the highly stable design more balanced, this levelling also prevents bucket spillage bucket making work more efficient.

HIGH EFFICIENCY FILTER

The filter restricts dust and particles from entering the engine, protecting the engine from wear, extending engine service life and improving engine efficiency.





OPERATOR'S COMFORT AND SAFETY

ROLL-OVER PROTECTION SYSTEM

The cab's high-strength ROPS ensures operator protection in a worst-case scenario.

FALLING OBJECT PROTECTION SYSTEM

In the extreme environments, the 375B/385B is designed to work in. The choice of Falling Object Protection System (FOPS) is an invaluable addition to operator safety.

COMFORT OPERATING CONDITION

Adjustable seat with shock absorption and optional high - grade seat provide utmost comfort to the operators. The cab is equipped with easy-pull and easy-secure side windows. Other options include radio with MP3.

CONVENIENT TO CONTROL

Ergonomic low-effort pilot control joysticks reduce operator's fatigue. The switches on the joysticks control the auxiliary kits by fingertips.



PART OF YOUR PERFORMANCE

No matter where you are in the world, we can ensure **fast and efficient** parts support to keep you going.



We know that what you want is to be confidence in your machinery. So we make sure we can always get what you need without delay, without fail, without excuses. Anywhere, and at any time. That's more than our goal. That's our pledge.

LiuGong engineering sets high standards and all parts are rigorously tested to ensure they can meet the rigid quality specifications required for long lasting performance.

READY FOR ANY JOB

LiuGong provides a range of purpose designed attachments, hitches and tools for your 375B/385B to give you increased versatility for any job site. In - cab dial - in hydraulic flow settings through the display screen optimizes the attachment performance.



BUCKETS



PICK-UP BROOM



PLANDER



BREAKER

EASY FOR MAINTENANCE

24 DEGREE TAPERED SEALS WITH O-RINGS

24 degree tapered seals with O-rings are fitted on hose connections to eliminate hydraulic leakage. The excellent design contributes to your machine's uptime and reduces service costs by providing a 100% leak free joint.

CAB TILT

The entire cab can easily be tilted backward by one person with 80 degrees to provide adequate space for the replacement of engine fuel filter, hydraulic oil filter, and more.

EXCELLENT LAYOUT

The hydraulic pipes and electrical wires are well reorganized and positioned to provide adequate space for daily inspection and convenient maintenance.

All fuseboxes and relays are centralized and easily accessible.

REAR SERVICE ACCESS

Rear hood provides adequate space for adding diesel or hydraulic oil, replenishing engine oil and anti-freeze fluid, replacing the air filter, draining the fuel water separator.





WHERE YOU NEED US WHEN YOU NEED US

LiuGong is committed to providing **reliable** and **tough** equipment combined with dependable service to customers **across the globe**.



GLOBAL NETWORK

We offer local support through our extensive dealer network in more than 130 countries. Our dealers and customers are supported by 10 regional subsidiaries and 9 global parts centers, all offering expert training, parts and service support.

PROFESSIONAL ADVICE

No matter the job, we can help you choose the right machine, with the right specifications, options and attachments for your business. We are committed to ensure maximum uptime and lowest cost of ownership to ensure you get good profitable return from your equipment.

SERVICE AGREEMENTS

At LiuGong, we offer service agreements to support your business needs and help you take control of all your costs. Talk to us today.



PERFORMANCE

Operating weight	375B 3,100 kg (6,820 lb) 385B 3,750 kg (8,267 lb)
Static Tipping Load	375B 1,730 kg (3814 lb) 385B 2,090 kg (4,608 lb)
Rated Operating Capacity	375B 865 kg (1,900 lb) 385B 1,045 kg (2,304 lb)
Boom Breakout Force	375B 18.5 kN (4,159 lbf) 385B 20.3 kN (4,566 lbf)
Bucket Breakout Force	375B 20.4 kN (4,586 lbf) 385B 29.8 kN (6,705 lbf)
Bucket Capacity	375B 0.45 m ³ (0.59 yd ³) 385B 0.5 m ³ (0.65 yd ³)

ENGINE

Emission rating	EU Stage V
Make	Yanmar
Model	375B 4TNV98C-PLYS 385B 4TNV98CT-NLYS
Gross Power	375B 49.9 kW (67 hp / 68 ps) @ 2,400 rpm 385B 53.7 kW (72 hp / 73 ps) @ 2,400 rpm
Peak Torque	375B 241 N·m (64 lbf·ft) @ 1,625 rpm 385B 291 N·m (77 lbf·ft) @ 1,625 rpm
No. of Cylinders	4
Displacement	3.3 L (201 in ³)
Cooling Type	Water

ELECTRICAL SYSTEM

System Voltage	12 V
Alternator Output	85 amps

TIRES

Ply Type	Vacuum
Tire Size	375B 10-16.5-10PRTI200 385B 12-16.5-12PRTI200
Ply Rating	375B 8 385B 12

DIMENSIONS

A. Maximum Hinge Pin Height	375B 2,923 mm (115.4 in) 385B 3,278 mm (129.1 in)
B. Dump Clearance at Full Height	375B 2,220 mm (87.6 in) 385B 2,572 mm (101.3 in)
D. Ground Clearance	375B 204 mm (8.0 in) 385B 200 mm (7.9 in)
E. Wheelbase	375B 1,087 mm (42.9 in) 385B 1,334 mm (52.5 in)
G. Overall Length without Bucket	375B 2,650 mm (104.6 in) 385B 2,973 mm (117 in)
H. Overall Height to Top of Cab	375B 1,940 mm (76.6 in) 385B 2,034 mm (80.1 in)
L. Overall Length with Standard Bucket	375B 3,432 mm (135.4 in) 385B 3,851 mm (151.6 in)
R1. Maximum Roll-back Angle at Full Height	375B 95° 385B 99°
R2. Bucket Rollback at Ground Level	30°
R3. Maximum Dump Angle at Full Height	375B 40° 385B 39°
R4. Angle of Departure	375B 26° 385B 27°
R5. Front Clearance Radius with Bucket	375B 1,800 mm (71.0 in) 385B 2,339 mm (92 in)
R6. Front Clearance Radius without bucket	375B 1,365 mm (53.9 in) 385B 1,414 mm (55.7 in)
W2. Wheel Tread	375B 1,335 mm (52.7 in) 385B 1,536 mm (60.5 in)
L1. Dump Reach at Full Height	375B 540 mm (21.3 in) 385B 587 mm (23.1 in)
Maximum Working Height at Full Height	375B 3,774 mm (148.9 in) 385B 4,176 mm (164.4 in)
Overall Width with Standard Bucket	375B 1,830 mm (72 in) 385B 1,905 mm (75 in)
Overall Width without Bucket	375B 1,576 mm (62.2 in) 385B 1,850 mm (72.8 in)

WORKING HYDRAULICS

Standard Flow	375B 79.2 L (20.9 gal)/min 385B 91.2 L (24.1 gal)/min
Optional High Flow	375B 124 L (32.8 gal)/min 385B 132.5 L (35 gal)/min
Hydrostatic Pressure	21 MPa (3,045 psi)
System Type	Open
Cycle Time, total	375B 8.6 s 385B 9.5 s
Raise	4.2 s
Dump	375B 2.3 s 385B 2.8 s
Lower (Empty, Float Down)	375B 2.1 s 385B 2.5 s

TRAVELLING HYDRAULICS

System Type	Closed
Hydrostatic Pressure	35 MPa (5,075 psi)
Drive Chain Size	375B 80 HS 385B 100 HS
Max Travel speed	375B 10.5 km/h (6.5 mph) 385B 11.3 km/h (7 mph)
Optional Max Travel Speed	375B 17.4 km/h (10.8 mph) 385B 22.6 km/h (14 mph)

SERVICE CAPACITIES

Fuel Tank	375B 100 L (26.4 gal) 385B 110 L (29 gal)
Engine Oil	9.4 L (2.5 gal)
Cooling System	375B 13 L (3.4 gal) 385B 20 L (5.4 gal)
Hydraulic Reservoir	375B 52 L (13.7 gal) 385B 60 L (15.9 gal)
Hydraulic System Total	375B 70 L (18.5 gal) 385B 80 L (21.1 gal)
Chain Tanks, Each	375B 8 L (2.1 gal) 385B 13 L (3.4 gal)

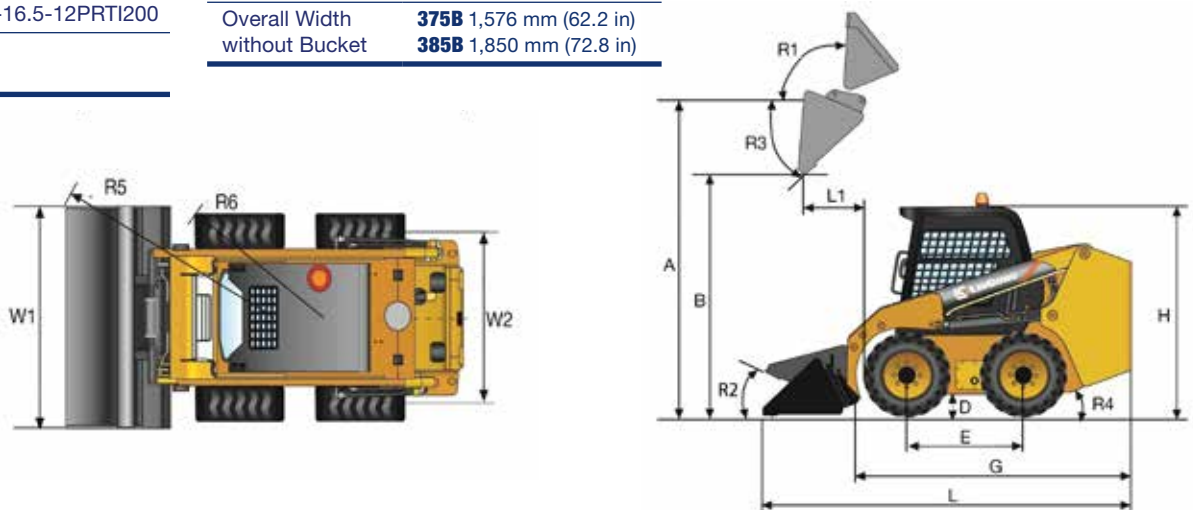

STANDARD EQUIPMENT

ENGINE SYSTEM

- Yanmar diesel engine, four cylinders
- EU Stage V emission standard

375B

- Yanmar 4TNV98C-PLYS
- Fuel tank 100 L (26.4 gal)

385B

- Yanmar 4TNV98CT-NLYS
- Fuel tank 110 L (29 gal)

TIRES

- Tubeless tire

ATTACHMENT

- Quick coupler

375B

- General bucket 0.45 m³ (0.59 yd³)

385B

- General bucket 0.5 m³ (0.65 yd³)

OPERATOR ENVIRONMENT

- Open cab with FOPS & ROPS
- Standard seat with 2 in seat belt
- CE Extinguisher
- Hand throttle
- Control safety interlock

TRANSMISSION SYSTEM

- Hydraulic brake
- Single speed motor

HYDRAULIC SYSTEM

- Hydraulic one-way self-leveling
- Auxiliary hydraulic pipe

OTHERS

- Pilot Control
- English decals
- CE extinguisher
- North American Decals
- CE Decals

OPTIONAL EQUIPMENT

OPERATOR ENVIRONMENT

- Enclosed cab, ROPS / FOPS
- AC and heater
- Foot throttle
- Radio with MP3
- Rear view mirrors
- Rotating beacon

TIRES

- Tire chains

375B

- Solid tire 31 x 10 x 16

385B

- Tubeless tire 14-17.5 14 PR
- Solid tire 33 x 12 x 20

HYDRAULIC SYSTEM

375B

- High flow 124 L (32.8 gal)/min

385B

- High flow 132.5 L (35 gal)/min

ATTACHMENTS

General bucket

- 0.4 m³ (0.52 yd³), 1,630 mm (64.3 in) width
- 0.4 m³ (0.52 yd³), bolt-on cutting edge
- 0.45 m³ (0.59 yd³), bolt-on teeth
- 0.5 m³ (0.65 yd³), bolt-on teeth

4 in 1 bucket

- 0.45 m³ (0.59 yd³), 1,880 mm (74 in) width
- 0.45 m³ (0.59 yd³), bolt-on teeth
- 0.4 m³ (0.52 yd³), 1,630 mm (64.2 in) width

Rock bucket

- 0.4 m³ (0.52 yd³), 1,880 mm (74 in) width

Pick-up broom

Cold planer

- Working width 450 mm (17.7 in)

Snow blade

- Swing angle of ±30°

Grapple bucket

- Grapple diameter from 350 to 650 mm (13.8 to 25.6 in)

Pallet fork

- Teeth length 1,070 mm (42.1 in)

Hydraulic hammer

- SOOSAN SB40

Material handling arm

Trencher

- Working width from 100 to 300 mm (3.9 to 11.8 in), max. depth 900 mm (35.4 in)

Wear resistant drill pipe

- Length 1,600 mm (63 in) and hole diameter 500 mm (19.7 in)

Rock drill pipe

- Length 1,600 mm (63 in) hole diameter 500 mm (19.7 in)

Arc-bucket

- 0.45 m³ (0.59 yd³), width 1,550 mm (61 in)

Snow blower

- Working width 1,830 mm (72 in)

Single excavator arm

- Max. depth 1,886 mm (74.3 in)

Vibratory drum compactors

- Working width 1,730 mm (68.1 in)

OTHERS

- License plate frame
- Other English decals
- Counterweight, 80 kg (177 lb)

385B

- Double speed motor



Guangxi LiuGong Machinery Co., Ltd.
No. 1 Liutai Road, Liuzhou, Guangxi 545007, PR China
T: +86 772 388 6124 E: overseas@liugong.com
www.liugong.com

Like and follow us:



LG-PB-375B/385B-Stage V-12-07032022-ENG

The LiuGong series of logos herein, including but not limited to word marks, device marks, letter of alphabet marks and combination marks, as the registered trademarks of Guangxi LiuGong Group Co., Ltd. are used by Guangxi LiuGong Machinery Co., Ltd. with legal permission, and shall not be used without permission. Specifications and designs are subject to change without notice. Illustrations and pictures may include optional equipment and may not include all standard equipment. Equipment and options varies by regional availability.