

# 19sk



Concrete solutions. Always.

Engine 4TNV98CT

Engine power 53,7 kW - 73,0 HP

Operating Weight 4.350 kg

 **EUROCOMACH**<sup>®</sup>

# 19sk

Operating weight	kg	4.350
------------------	----	-------

## ENGINE

Type	YANMAR 4TNV98CT - STAGE 5	
Max. Power (2.600 rpm)	kW - HP	53,7 - 73,0
Max. torque	Nm	291 (1.625 rpm)
Displacement	cc	3.319
Number of cylinders	n°	4
Cooling	Liquid	
Consumption	lt/h	11
Alternator	V (A)	12 (80)
Battery	V (Ah)	12 (100/850)

## HYDRAULIC SYSTEM

Pump type	N° 1 with variable displacement axial piston pumps with load sensing REXROTH	
Pump capacity	lt/min	160
Max. circuit calibration pressure	bar	280
High Flow System (standard):		
Max. capacity	lt/min	160
Max. pressure	bar	280

## TRANSMISSION

Type	Hydrostatic with electro-hydraulic tandem pump and radial pistons REXROTH gearboxes	
Travelling speed	km/h	1a : 0 ÷ 9,0 / 2a : 0 ÷ 18,0
Max. Traction force	daN	4.450
Dimensions tires	12 x 16.5	

## BRAKES

Service brakes	Hydrostatic	
Parking brakes	Negative with multiple disks into oil bath, integrated on the gearboxes at electrohydraulic control	
Emergency brakes	Electrohydraulic control, acting on parking brakes (integrated on the gearboxes)	

## PERFORMANCES

Upsetting load (ISO 14397)	kg	2.920
Operating load (ISO 14397, no more than 50% of tipping load)	kg	1.450
Bucket breaking force	daN	3.985
Standard bucket capacity	m <sup>3</sup>	0,56
Standard bucket width	mm	1.840
Max. slope	60% - 30°	

## FILLINGS

Fuel tank	lt	100
Hydraulic oil tank	lt	55
Hydraulic circuit capacity	lt	93
Cooling system capacity	lt	12
Engine oil	lt	10,2

## CONTROLS

Type	Ergonomic joystick with electronic controls and onboard safety lock	
Translation	Electro-hydraulic control on left hand joystick	
Services	Electric control with right hand joystick for lifting and bucket	
Lifting mechanism	Vertical lifting boom with a standard self-levelling system for the bucket (only for boom rising)	

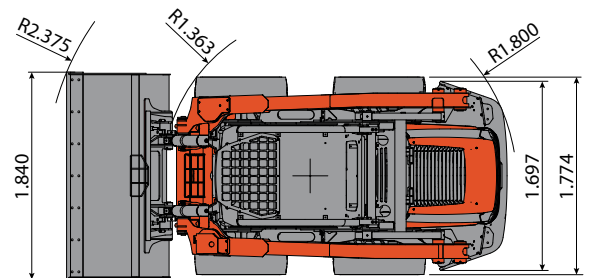
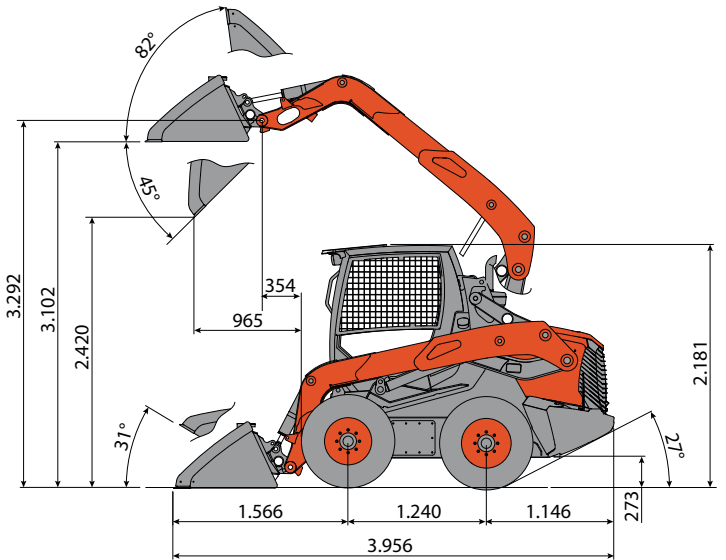

- Homologation for road traffic (only Italy).
- The ROPS (ISO 3471) – FOPS (ISO 3449) engineer standards manufactured cab or canopy.
- Front and rear lights for night-road use and working.

 **EUROCOMACH®**