



# CONSTRUCTION LINE **LG**

## LEVELING GRADER

The grader is ideal for making **precise plans** for **roads, parking lots, sports facilities** and **squares**.

The **sturdy structure** allows to have a **great resistance to the shocks** that inevitably occur during the leveling work. The unique **stress absorption system** received by the spring grader allows a **large amount of material to be handled** for each pass without affecting the great stability that distinguishes it, thus allowing a **great speed of advancement**, with a consequent saving of time during work.

The two **sturdy front wheels** are completely free and **swivel 360 °** to provide **additional stability**. The front wheels are fully free and rotatable.

The grader is characterized by all the **hydraulic movements**:

the translation, the inclination of the two independent sides to each other in order to perform double slopes and the rotation of the blade.

All **movements** are **regulated by proportional solenoid valves** that allow **great precision** both with manual operation and with automatic operation by means of a laser system.



The GF Gordini grader **can be combined with all laser systems** of any brand, both 2D and 3D.

As an option, on request, it is possible to have the manually or hydraulic **operated side wings** kit which guarantees greater versatility to the grader: side wings positioned at 90 ° or 45 ° with respect to the blade to contain the material during advancement, in a straight position to widen the blade itself.





Model	LG 210 P	LG 240 P	LG 250 P	LG 270 P
-------	----------	----------	----------	----------

Technical data	um				
Blade width (A)	mm	2133	2400	2500	2700
Oil flow min-max	lt/min	20-80			
Oil pressure min-max	bar	120-250		140-250	
Weight standard configuration	Kg	730	750	970	1000
Solenoid valve, blade tilt and adjustment skid		proportional <sup>(1)/(2)</sup>			
Hydraulic lateral sideshift of the right/left blade (D)	mm	± 400		± 450	
Hydraulic tilt of the right/left blade (B)		± 30°			
Hydraulic rotation of the right/left blade (C)		± 35		± 40	
E	mm	860	962	980	1080
F	mm	1466	1600	1700	1800
G	mm	1720	1924	686	2153
H	mm	578	643	713	
L	mm	165	165	400	
M	mm	1320		1397	
N	mm	2220		2363	
	ton	2,5-3,6		3,5-5,5	
	ton	3,0-4,4		4,2-7,8	
	ton	3,2-5,0		4,8-8,2	

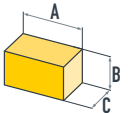
	Overall size	A cm	173	184	195	215
	in standard	B cm	132	132	140	140
	configuration	C cm	222	222	236	236

<sup>(1)</sup>Using the grader LG mod. "P" with the manual control ON-OFF the blade movement is ON-OFF. The proportional movement of the blade occurs only with the proportional laser automation system.

<sup>(2)</sup>Using the grader LG mod. "P" with the manual control PROPORTIONAL the movement of the blade is PROPORTIONAL.

WORKING DIMENSIONS

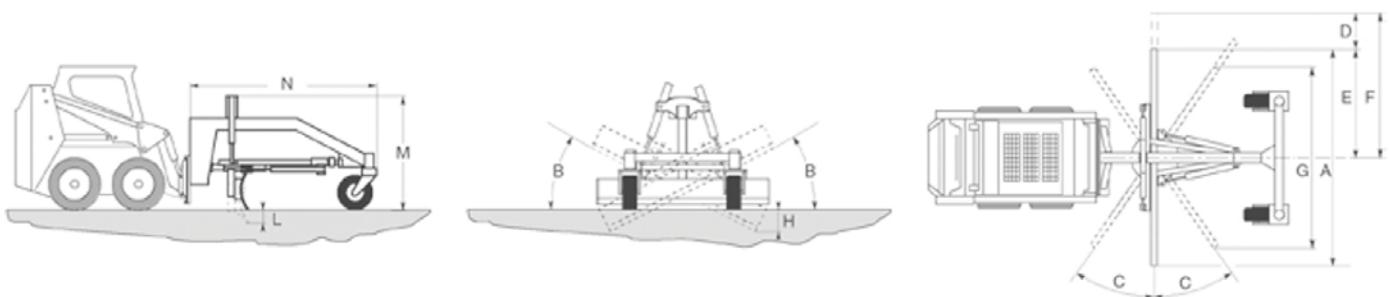



# CONSTRUCTION LINE **LG** LEVELING GRADER

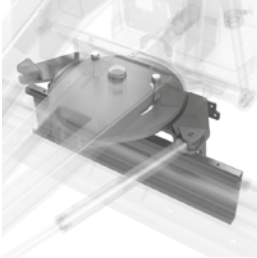

## CENTRAL FIFTH WHEEL WITH BUTTONHOLES FOR REGULATION AND ELIMINATION OF JUGGLE

The central wheel, the **fundamental pivot** of the grader, held by a strong **central pin** locked with a nut. It can be adjusted (tighten) by **two screws** positioned laterally, which allow you to **limit to the maximum the juggle** that inevitably is created after the many hours of work. Unique in its kind, this system allows the grader to **maintain an excellent precision** even after many hours of use, also **limiting vibration** and loss of efficiency.

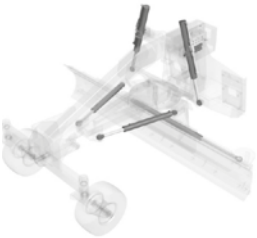

## RIGHT AND LEFT INCLINATION, ROTATION AND LATERAL TRANSLATION TOTALLY HYDRAULIC, WITH PROPORTIONAL SOLENOID VALVE

In order to obtain an **extremely precise performance** by working both in manual mode, but even more in automatic mode, the grader is equipped with **resistant and precise proportional hydraulic valves**.

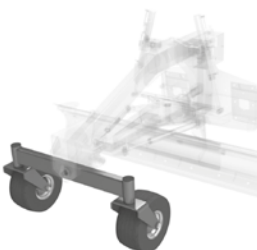

## ROBUST FRONT WHEELS AND FRONT PART TRANSVERSELY MOVABLE

The front part is fundamental because it "bumps" the heaps of material to be levelled, as well as giving **great stability and strength** to all the equipment, which results in **precision and speed** of advancement. The grader grader consists of a **sturdy front axle** that can be tilted transversely to allow the different inclinations of the ground to be absorbed. In addition, the **swivel wheels** (to 360°) are complete with **robust bearings** inside the hub, to withstand even the most violent stresses and the most heavy use



### BOLTED PLATE

The plate is bolted and **interchangeable**. The grader has a **smooth and perforated plate**, on which you can place the dedicated attachment for the operating machine, giving it **great versatility**, allowing it to be mounted on machines with different connections, simply by replacing the mounting plate.

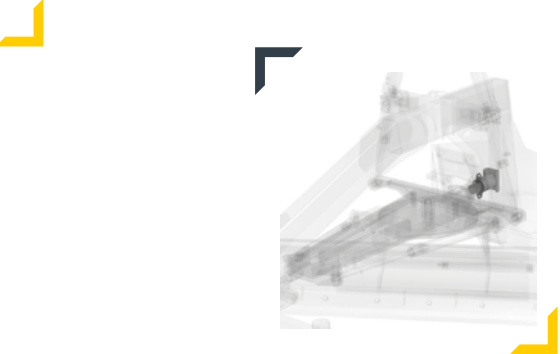
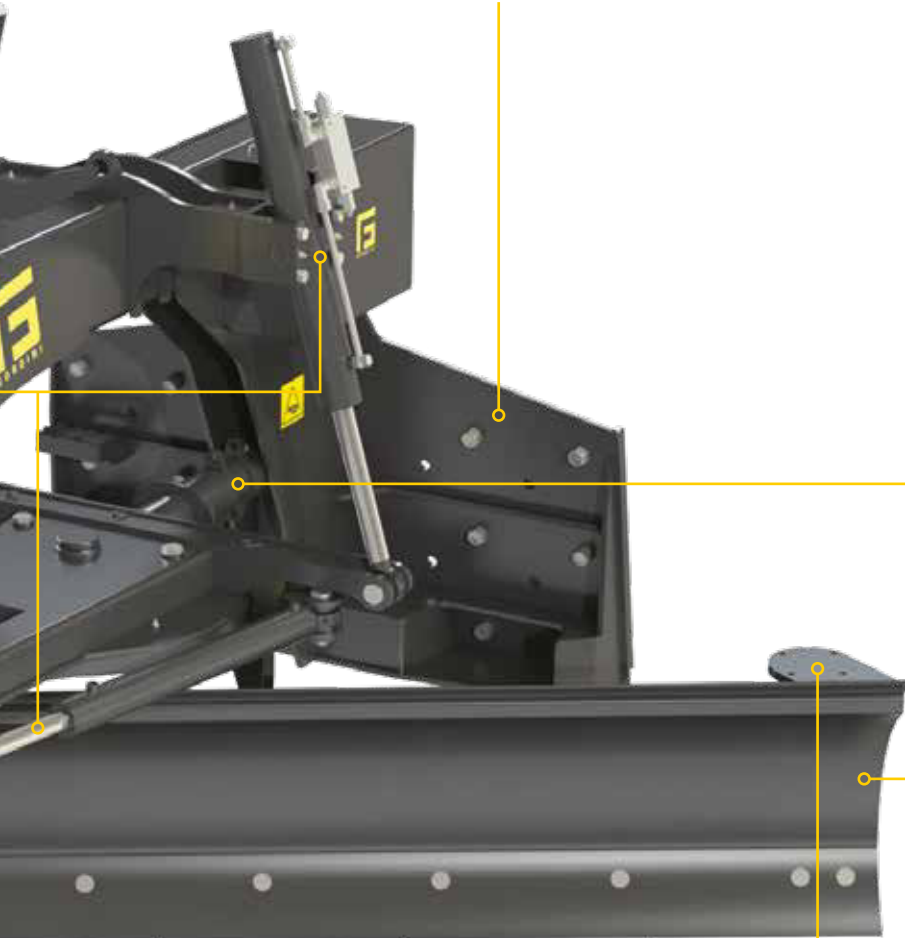

### CENTRAL SPRING SYSTEM FOR SHOCK ABSORPTION THAT GUARANTEES GREAT STURDINESS AND ALLOWS GOOD FORWARD SPEED

The GF grader is built in such a way as to have a **system that can withstand any kind of impact**, as well as **absorb** the inevitable **stresses** during work. This guarantees **great resistance** over time and allows a **high advancement speed**, a fundamental element for users.

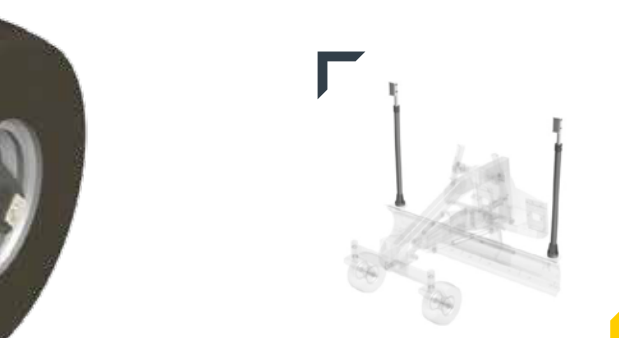

### POSSIBILITY OF COMBINING WITH ALL LASER AUTOMATION SYSTEMS ON THE MARKET

The grader can be combined with any brand of laser. In order to obtain optimal **precision** and **working speed**, the **proportional solenoid valves can be interfaced** with any brand of laser automation. **Preparation kits** can be supplied for the most popular laser brands, in order to make the application of the sensors immediate and simple.

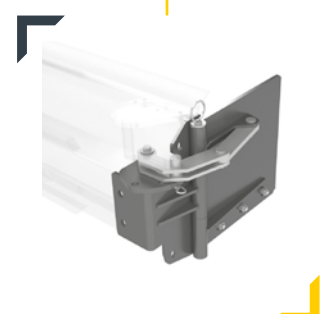

### MECHANICAL SIDE EXTENSIONS (optional)

On request it is possible to add two side spreaders (one on each side), with the possibility of being added at a later time by means of a convenient drilling. They can be manually **set in three positions: fully open** (allowing the blade to extend 30cm per side), **90°** to contain the material and **45°** to obtain an intermediate position. Hydraulic extenders are also available.