



MST

TELESCOPIC HANDLER

Model: **MIH 13.35**



Technical Specifications

ENGINE

| | | |
|--------------------------|--|--|
| Brand & Model | PERKINS 904J-E36TA @ Commonrail | PERKINS 904J-E36TA @ Commonrail |
| Emission | Stage 5 | Stage 5 |
| No. Of Cylinders | 4 | 4 |
| Displacement | 3621 ccm | 3621 ccm |
| Power Rating | 75 hp / 55,4kW@2300rpm | 100 hp / 74,4kW@2300rpm |
| Torque Rating | 424Nm@1200rpm | 430Nm@1500rpm |
| Aspiration | Commonrail with direct injection @ Turbo charged aftercooler | Commonrail with direct injection @ Turbo charged aftercooler |
| Cooling | Water cooled | Water cooled |

TRANSMISSION

| | |
|--------------------------------|--|
| Type Of Transmission | Hydrostatic transmission with variable piston pump @ 2-speed |
| Gearbox Speed (Fwd/Rvs) | 2 / 2 |
| Max. Travelling Speed | 35 km/h (75 kW) / 30 km/h (55 kW) |
| Steering Modes | 2 WS, 4WS, 4WS-Crab |

HYDRAULIC SYSTEM

| | |
|---------------------------|--|
| Hydraulic Pump | Load sensing type variable piston pump |
| Main Control Valve | Electro-hydraulic control |
| Max. Flow | 100 l/min |
| System Pressure | 240 bar |
| Joystick Control | 7 in 1 @ FNR & Gear up-down shift |

FLUID CAPACITIES

| | |
|--|----------|
| Fuel Tank | 120 l |
| Hydraulic Tank | 110 l |
| Standart Machine Operating Weight | 10.050kg |

CYCLE TIMES

| | |
|-------------------|---------|
| Lifting | 12.50 s |
| Lowering | 10.00 s |
| Extension | 15.00 s |
| Retraction | 9.50 s |
| Crowd | 3.50 s |
| Dump | 3.50 s |

AXLES, BRAKE SYSTEM and TYRES

| | |
|--------------------------------|---|
| Axles | LSD type front axle with transverse levelling ($\pm 10^\circ$) control in the cab & swinging type rear axle |
| Brake System | Front / Rear multi-discs type oil bath & with inching |
| Parking Emergency Brake | Negative parking brake (SAHR) |
| Tires | 405/70-24 |

NOISE

| | |
|---------------------------------------|-----------|
| Noise at Driving Position LpA* | 80 db(A) |
| Noise to Environment LwA* | 102 db(A) |

PERFORMANCE

| | |
|---|------------------|
| Model Family | 13 M |
| Max. Lifting Capacity | 3500 kg |
| Max. Lifting Capacity at Full Height | 3500 kg |
| Capacity at Max. Forward Reach | 1250 kg |
| Max. Lifting Height | 12.55 m |
| Max. Forward Reach | 8.65 m |
| Stabilizers | 2 Units in front |
| Chassis Levelling | $\pm 10^\circ$ |
| Max. Towable Trailer Weight (kg) (With/Without Brake)*** | 3000-14000 kg |

Load Chart (Stabs Down)

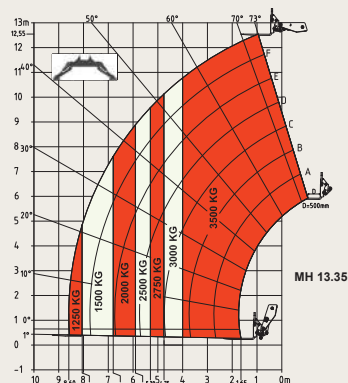

Load Chart (Stabs Up)

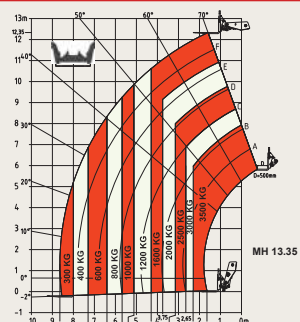

Optional / EN-280

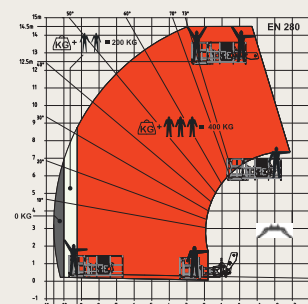

MST

TELEHANDLER

MH 13.35



Chain Synchronized
Boom System

With

Single Extension
Piston

DIMENSIONS

| | |
|---|-----------------------|
| A-Wheelbase | 3000 mm |
| B-Overall Length To Front Face of Tyres | 4814 mm |
| C-Overall Length To Carriage | 5954 mm |
| D-Ground Clearance | 400 mm |
| E-Inside Tyre Width | 1930 mm |
| F-Overall Width | 2345 mm |
| G-Overall Cab Width | 971 mm |
| H-Overall Height | 2450 mm |
| I-Tow Bar | 80 mm |
| J- Turning Radius (Engine Hood) | 1690 mm |
| K- Turning Radius (Over Tyres) | 4395 mm |
| Standart Forks *** | 120 x 50 x 1200 mm |
| Chassis Levelling | ±10° / Right and Left |

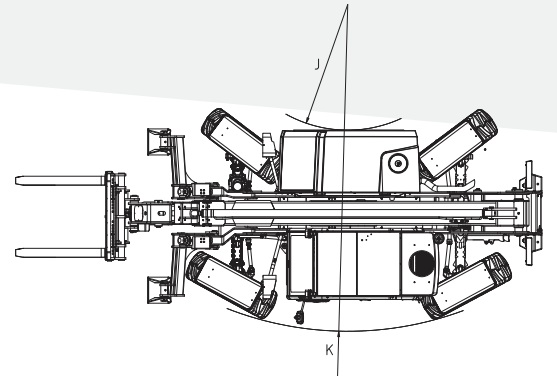
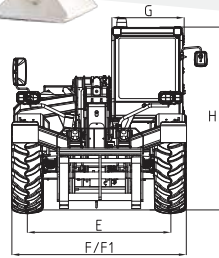
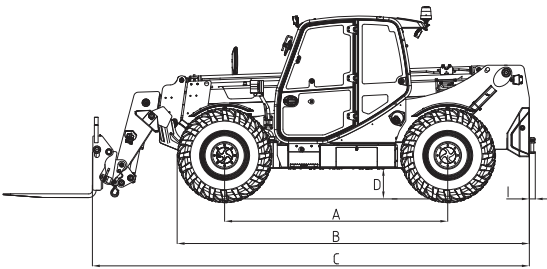

The information, visual, model and equipments features indicated in this document can be offered as standard or optional depending on the country and region. MST, reserves all the rights to make changes without notice for the information, values and designs contained this document.

MST CONSTRUCTION EQUIPMENT YATIRIM A.Ş.

4. Organize Sanayi Bölgesi 83426 Cad. No:1

Başpınar / Gaziantep / TÜRKİYE

Phone: +90 342 211 59 00 444 2 767

Fax: +90 342 357 00 32 export@mst-tr.com



A MEMBER OF

ASKO

CORPORATION

mstismakinalari mstismakinalari MST İş Makinaları

mstmakina MST İş Makinaları

www.mst-tr.com

www.asko.com.tr